

STANDARD NOZZLE BODY

◆ High Quality Steel

- ◆ 1 3/4" - 8 Thread
- ◆ .750" Rear Opening
- ◆ Sizes from "0" heated length
- ◆ 4" to 26" OAL
- ◆ 1 1/2" O.D.



Replaceable Tip Nozzle Body, Externally heated, industry standard 7/8" - 14 thread can be used with general purpose, nylon, free flow or extension nozzle tip.

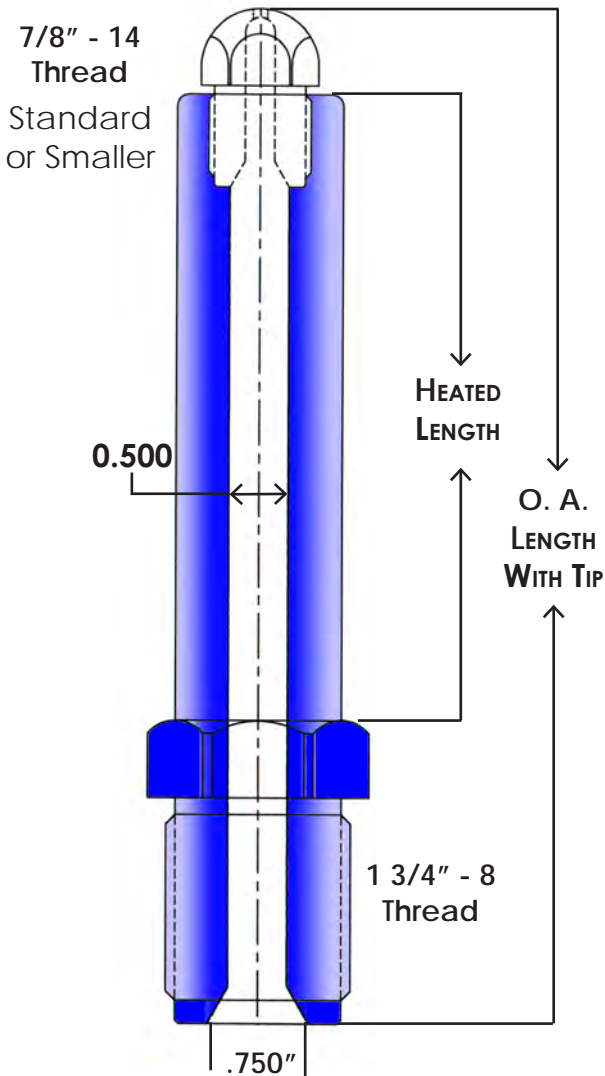

Part Number	Length with Tip	Heated Length
PCNA4	4"	0"
PCNA5	5"	1 1/2"
PCNA6	6"	2 1/2"
PCNA7	7"	3 1/2"
PCNA8	8"	4 1/2"
PCNA9	9"	5 1/2"
PCNA10	10"	6 1/2"
PCNA12	12"	8 1/2"
PCNA14	14"	10 1/2"
PCNA16	16"	12 1/2"
PCNA18	18"	14 1/2"
PCNA20	20"	16 1/2"
PCNA22	22"	18 1/2"
PCNA24	24"	20 1/2"
PCNA26	26"	22 1/2"

See page #31 for Thermocouple Well options.

VAN DORN NOZZLE BODY

- ◆ High Quality Steel
- ◆ 1 3/4" - 8 Thread ◆ 1.250" Rear Opening
- ◆ Sizes from "0" heated length ◆ 4" to 26" OAL
- ◆ Shot Size 12 oz. and Over ◆ 1 1/2" O.D.

Replaceable Tip Nozzle Body, Externally heated, industry standard 7/8" - 14 thread can be used with general purpose, nylon, free flow or extension nozzle tip.

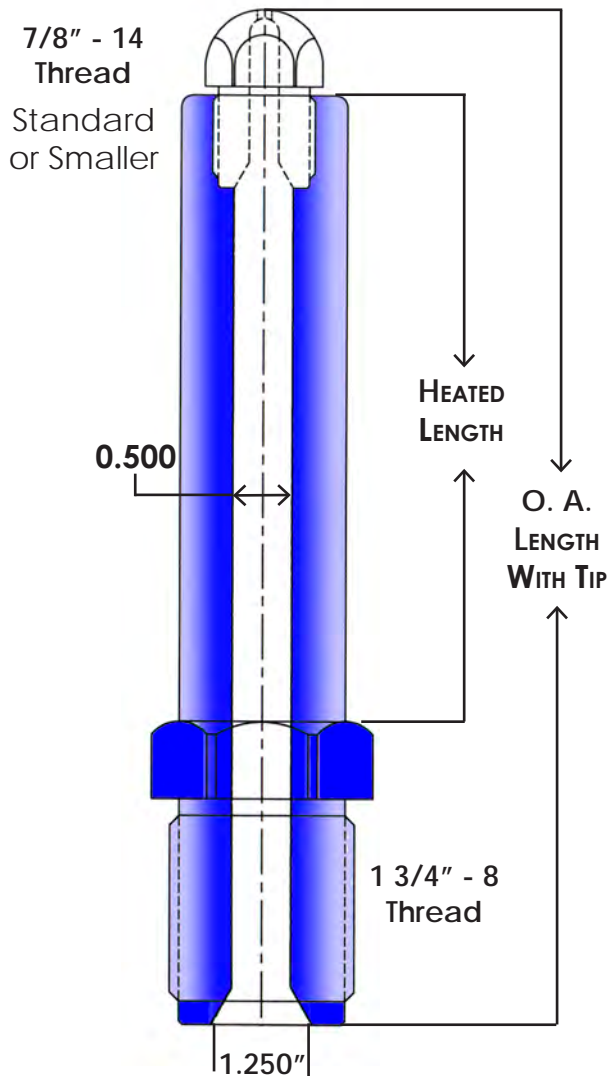

Part Number	Length with Tip	Heated Length
PVDA4	4"	0"
PVDA5	5"	1 1/2"
PVDA6	6"	2 1/2"
PVDA7	7"	3 1/2"
PVDA8	8"	4 1/2"
PVDA9	9"	5 1/2"
PVDA10	10"	6 1/2"
PVDA12	12"	8 1/2"
PVDA14	14"	10 1/2"
PVDA16	16"	12 1/2"
PVDA18	18"	14 1/2"
PVDA20	20"	16 1/2"
PVDA22	22"	18 1/2"
PVDA24	24"	20 1/2"
PVDA26	26"	22 1/2"

See page #31 for Thermocouple Well options.

VAN DORN NOZZLE BODY

◆ High Quality Steel

- ◆ 1 1/4" - 12 Thread
- ◆ .750" Rear Opening
- ◆ Sizes from "0" heated length
- ◆ 4" to 26" OAL
- ◆ Shot Size 8 oz. and Under
- ◆ 1 1/2" O.D.

Replaceable Tip Nozzle Body, Externally heated, industry standard 7/8" - 14 thread can be used with general purpose, nylon, free flow or extension nozzle tip.

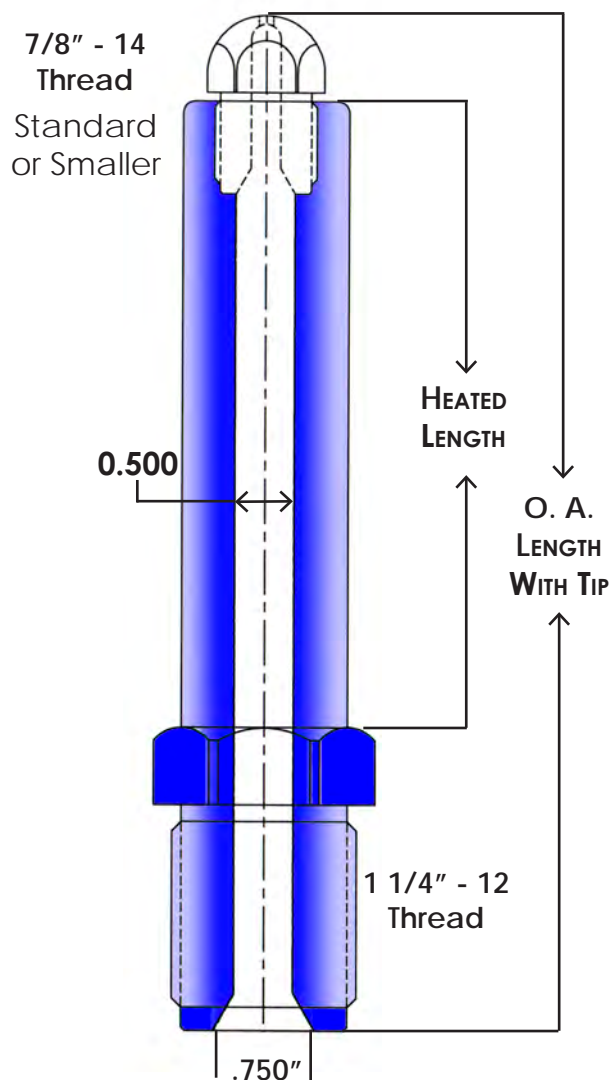

Part Number	Length with Tip	Heated Length
PVDB4	4"	0"
PVDB5	5"	1 1/2"
PVDB6	6"	2 1/2"
PVDB7	7"	3 1/2"
PVDB8	8"	4 1/2"
PVDB9	9"	5 1/2"
PVDB10	10"	6 1/2"
PVDB12	12"	8 1/2"
PVDB14	14"	10 1/2"
PVDB16	16"	12 1/2"
PVDB18	18"	14 1/2"
PVDB20	20"	16 1/2"
PVDB22	22"	18 1/2"
PVDB24	24"	20 1/2"
PVDB26	26"	22 1/2"

See page #31 for Thermocouple Well options.

1/2" BORE CUSTOM NOZZLE BODY

- ◆ High Quality Steel
- ◆ Thread Size up to 2" or 50mm
- ◆ Main Body 1 1/2" or Less
- ◆ Bore Size 0.500" or Less
- ◆ Nozzle Tip Thread 7/8" - 14 or Less

Small 1/2" Bore Size Custom Nozzle Bodies	
Rear (Machine Thread)	Up to 2" 50mm or Less
Nozzle Tip Thread	7/8-14 or Less
Bore size	0.500 or Less
Main Body	1 1/2" or Less

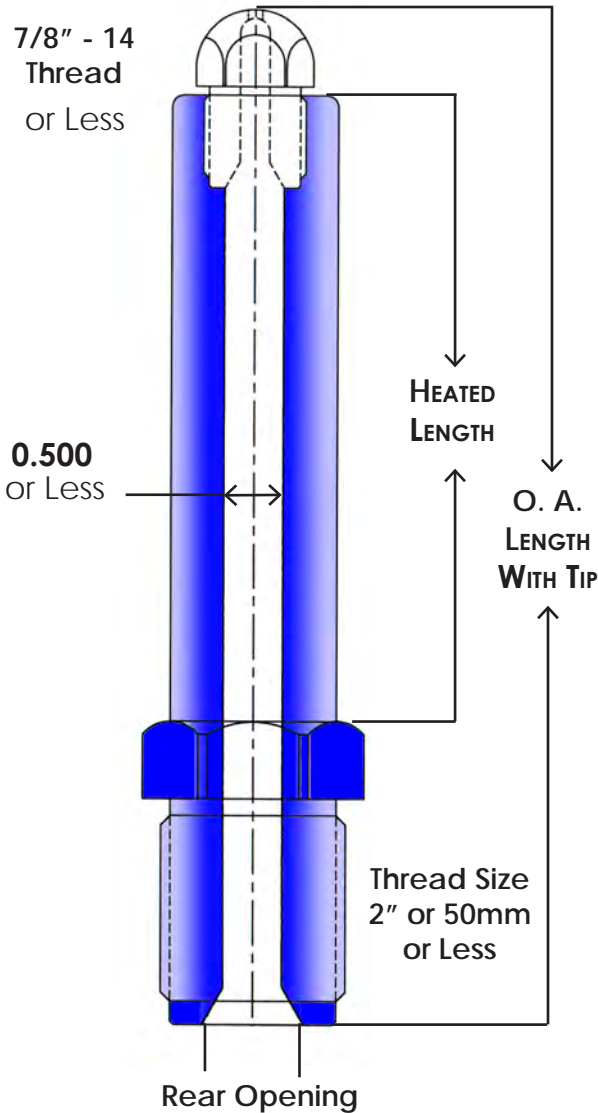

Length with Tip
4"
5"
6"
7"
8"
9"
10"
12"
14"
16"
18"
20"
22"
24"
26"

See page #31 for Thermocouple Well options.

3/4" BORE CUSTOM NOZZLE BODY

- ◆ High Quality Steel
- ◆ Thread Size 2 3/4" or 70mm or Less
- ◆ Main Body 1 3/4" to 2" or Less
- ◆ Bore Size 0.750 or Less
- ◆ Nozzle Tip Thread 1 1/4" - 12 or Less

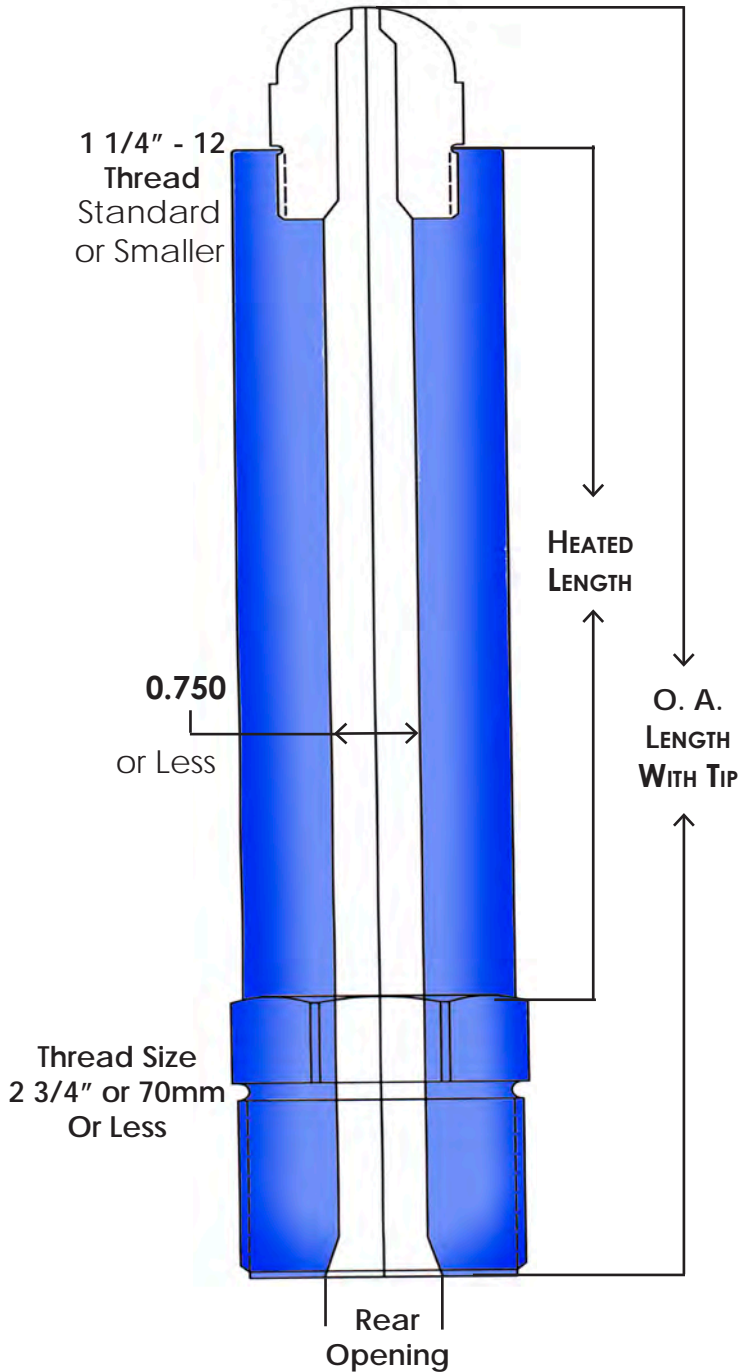

Medium 3/4" Bore Size Custom Nozzle Bodies	
Rear (Machine Thread)	2"-2 3/4" 50mm -70mm
Nozzle Tip Thread	1 1/4-12 or Less
Bore size	0.750 or Less
Main Body	1 3/4" - 2" or Less

Length with Tip
4"
5"
6"
7"
8"
9"
10"
12"
14"
16"
18"
20"
22"
24"
26"

See page #31 for Thermocouple Well options.

BIG CUSTOM NOZZLE BODY

◆ High Quality Steel

- ◆ Thread Size 2 3/4" to 3 1/2" or 70mm to 80mm
- ◆ Main Body 3 1/2" or Less
- ◆ Bore Size 1.00" or Less
- ◆ Nozzle Tip Thread Size 1 3/4" - 8 or Less

Large 1" Bore Size Custom Nozzle Bodies

Rear (Machine Thread)	2 3/4" - 3 1/2" 50mm - 85mm
Nozzle Tip Thread	1 3/4"-8 or Less
Bore size	1.00" or Less
Main Body	3 1/2" or Less

Length with Tip
4"
5"
6"
7"
8"
9"
10"
12"
14"
16"
18"
20"
22"
24"
26"

See page #31 for Thermocouple Well options.

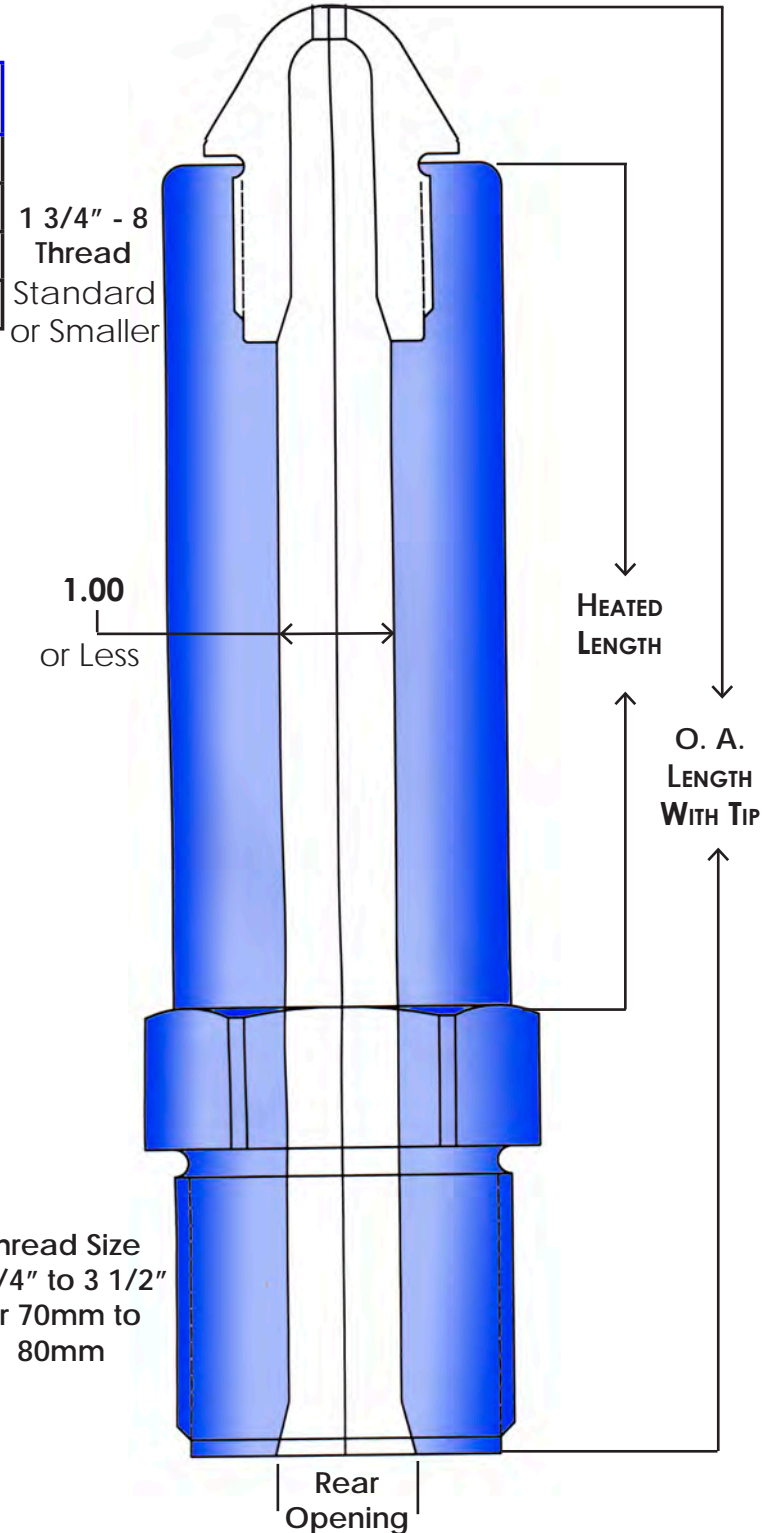

CUSTOM NOZZLE BODY CHART

Fax: 810.227.5566

Company Name: _____
 Contact Name: _____
 Address: _____
 City/State/Zip: _____
 Phone #: _____

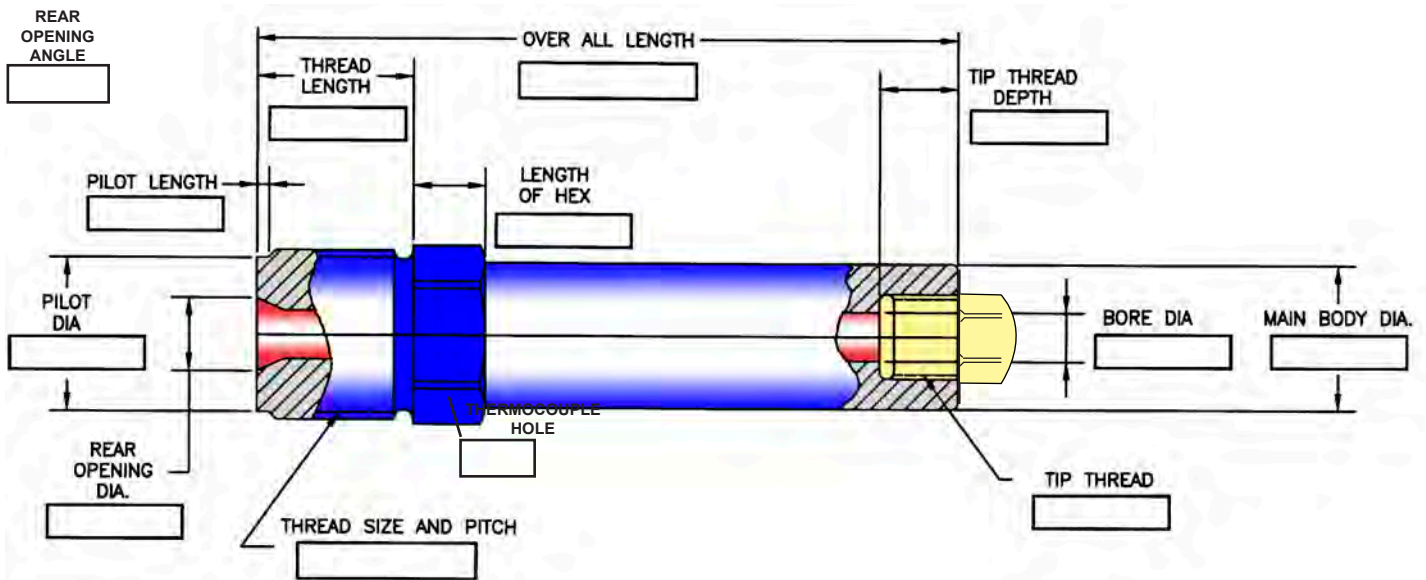
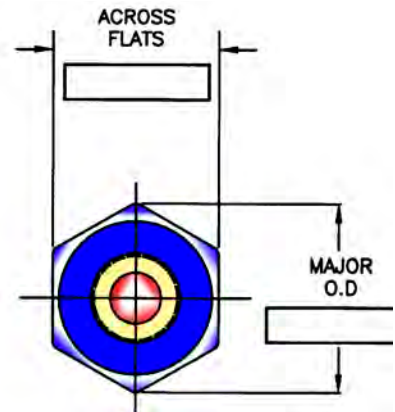

1. Overall Length _____	8. Bore Dia. _____
2. Thread Length _____	9. Main Body Dia. _____
3. Pilot Dia. _____	10. Tip Thread _____
4. Pilot Length _____	11. Across Flats _____
5. Rear Opening _____	12. Major O.D. _____
6. Length of Hex _____	13. Thread Size and Pitch _____
7. Tip Thread Depth _____	

Fax this page with information for your custom nozzle body.

Our nozzles are made from top quality alloy, stainless or tool steel to meet your special needs.



THERMOWELL OPTIONS

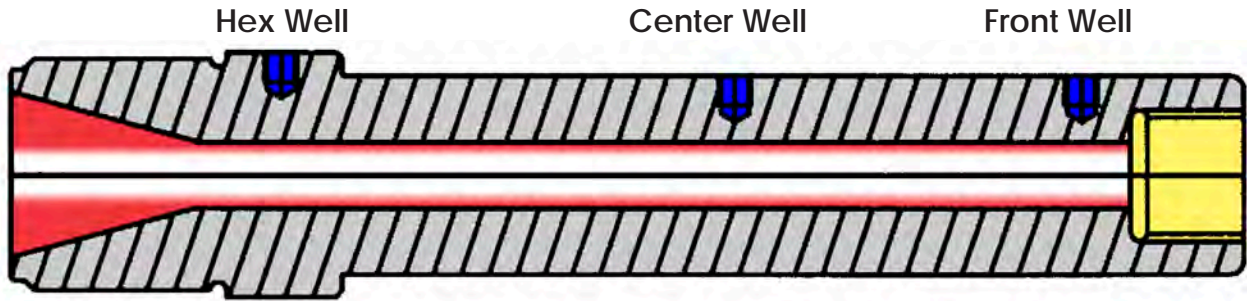

Option A

1/4 - 28
(Most Common)

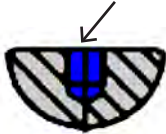

To be used with **5100** series T/C located on page #37

Add to Nozzle Part#:
For Hex - AH
For Center - AC
For Front - AF

Option B

M8 X 1.25
(Metric)

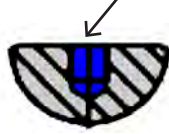

To be used with **5300** series T/C located on page #38

Add to Nozzle Part#:
For Hex - BH
For Center - BC
For Front - BF

Option C

1/8" - 27 N.P.T.
(in Hex Only)

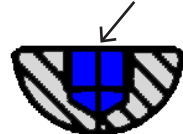

To be used with **1100 & 1112** series T/C located on page #39

Add to Nozzle Part#:
For Hex - CH
For Center - CC
For Front - CF

Option D

10 - 32
(Lug Type)



To be used with **Lug** series T/C located on page #42

Add to Nozzle Part#:
For Hex - DH
For Center - DC
For Front - DF

Option E

1/4 - 20
(Lug Type)

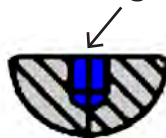

To be used with **Lug** series T/C located on page #42-43

Add to Nozzle Part#:
For Hex - EH
For Center - EC
For Front - EF

Option F

Custom
Size



Please provide custom Thread size: _____

Add to Nozzle Part#:
For Hex - FH
For Center - FC
For Front - FF