

THE NOZZLE SHOP

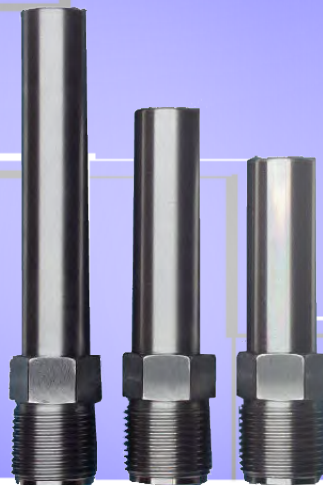

**Nozzle Tips, Nozzle Bodies, Valves,
MRO Items, Heaters,
Thermocouples, and so
much more**



AIC EQUIPMENT & CONTROLS, INC.
Plasti-Co

37 Summit Street, Brighton, MI 48116 (810) 227-2266 Fax: (810)-227-5566

TABLE OF CONTENTS

Page 1	Table of Contents
Page 2	General Purpose - Replaceable Nozzle Tips 1/2" & 3/4" Steel, Fast Heat Transfer Alloy
Page 3	Nylon - Replaceable Nozzle Tips 1/2" & 3/4" Steel, Fast Heat Transfer Alloy
Page 4	Full Taper - Replaceable Nozzle Tips 1/2" & 3/4" Steel, Fast Heat Transfer Alloy
Page 5	Full Radius Tips - 1 1/2" Long - 1/2" & 3/4" Steel - General Purpose, Nylon & Full Taper
Page 6	Full Radius Tips - 1 1/2" Long - 1/2" & 3/4" Fast Heat Transfer Alloy - General Purpose, Nylon & Full Taper
Page 7	Extended Full Radius Tips - 1 3/4" Long - 1/2" & 3/4" Steel - General Purpose, Nylon & Full Taper
Page 8	Extended Full Radius Tips - 1 3/4" Long - 1/2" & 3/4" Fast Heat Transfer Alloy - General Purpose, Nylon & Full Taper
Page 9	Extended Full Radius Tips - 2 1/2" Long - 3/4" Steel & Fast Heat Transfer- General Purpose
Page 10	Extended Tips - 7/8" - 14 thread, 2 3/4" Long - 1/2" & 3/4" Steel & Fast Heat Transfer General Purpose
Page 11	Extended Tips - 7/8" - 14 thread, 2 3/4" Long - 1/2" & 3/4" Steel & Fast Heat Transfer - Nylon
Page 12	Extended Tips - 7/8" - 14 thread, 3 1/4" Long - 1/2" & 3/4" Steel & Fast Heat Transfer General Purpose
Page 13	Extended Tips - 7/8" - 14 thread, 4" Long - 1/2" & 3/4" Steel & Fast Heat Transfer General Purpose
Page 14	Extended Tips - 7/8" - 14 thread, 5" & 6" Long - 1/2" & 3/4" Steel - General Purpose
Page 15	Extended Tips - 7/8" - 14 thread, 7" & 8" Long - 1/2" & 3/4" Steel - General Purpose
Page 16	"Big Nozzle Tips" - 1 5/8" Long - 1/2" & 3/4" Steel & Fast Heat Transfer - General Purpose
Page 17	"Big Nozzle Tips" - 1 5/8" Long - 1/2" & 3/4" Steel & Fast Heat Transfer - Full Taper
Page 18	"Big Nozzle Tips" - 3" Long - 3/4" Steel & Fast Heat Transfer Alloy - General Purpose
Page 19	"Big" Extended Tips - 4" & 5" Long - 1/2" Steel - General Purpose
Page 20	"Big" Extended Tips - 4" & 5" Long - 3/4" Steel - General Purpose
Page 21	"Big" Extended Tips - 1 1/4" -12 Thread, 6", 7" & 8" Long - 1/2" & 3/4" Steel - General Purpose
Page 22	Custom Nozzle Tips Various Configurations
Page 23	Custom Nozzle Tips Chart
Page 24	Standard Nozzle Body - 1 3/4" - 8 Thread
Page 25	Van Dorn Nozzle Body - 1 3/4" - 8 Thread
Page 26	Van Dorn Nozzle Body - 1 1/4" - 12 Thread
Page 27	1/2" Bore Custom Nozzle Body - Thread up to 2" or 50mm
Page 28	3/4" Bore Custom Nozzle Body - Thread less then 2 3/4" or 70mm
Page 29	BIG Custom Nozzle Body - Thread size 2 3/4" to 3 1/2" or 70mm to 80mm
Page 30	Custom Nozzle Body Chart
Page 31	Thermowell Options
Page 32	PE Heaters
Page 33	Al Heaters
Page 34	Ultra Nozzles - Internally Heated nozzles
Page 35	Ultra Nozzles - Internally Heated nozzles
Page 36	Industrial Thermocouples
Page 37	Nozzle Thermocouple - 5100 Series
Page 38	Nozzle Thermocouple - 5300 Metric Series
Page 39	Adjustable Depth Thermocouples
Page 40	Nozzle Underbands Center Style Thermocouples
Page 41	Nozzle Underbands Edge Style Thermocouples
Page 42	Lug Type Thermocouples - 3100
Page 43	Lug Type Thermocouples - 3200
Page 44	Nozzle Melt Thermocouples

STANDARD GENERAL PURPOSE REPLACEMENT NOZZLE TIP

1/2" Radius



3/4" Radius



- ◆ High Quality Steel or
- ◆ High Quality Copper Alloy
- ◆ General Purpose
- ◆ Thread Size 7/8" - 14
- ◆ 1-1/2" Length O.A.
- ◆ 1/2" & 3/4" Radius

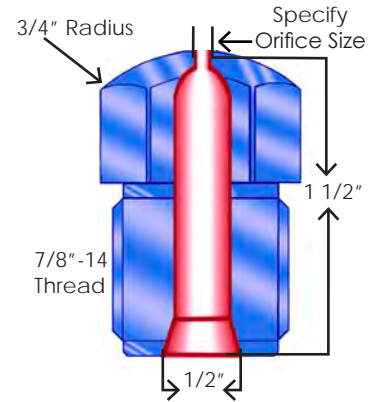
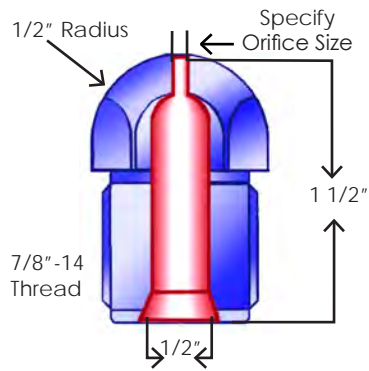

High Quality Steel								
Radius	Orifice	Part Number	Radius	Orifice	Part Number			
1/2"	1/16	0.062	3/4"	1/16	0.062	NTA-02GP-S		
	3/32	0.093		3/32	0.093	0.093	NTB-02GP-S	
	1/8	0.125		1/8	0.125	0.125	NTB-03GP-S	
	5/32	0.156		5/32	0.156	0.156	NTB-04GP-S	
	3/16	0.187		3/16	0.187	0.187	NTB-05GP-S	
	7/32	0.218		7/32	0.218	0.218	NTB-06GP-S	
	1/4	0.250		1/4	0.250	0.250	NTB-07GP-S	
	9/32	0.281		9/32	0.281	0.281	NTB-08GP-S	
	5/16	0.312		5/16	0.312	0.312	NTB-09GP-S	
	11/32	0.344		11/32	0.344	0.344	NTB-10GP-S	
	3/8	0.375		3/8	0.375	0.375	NTB-11GP-S	
	13/32	0.406		13/32	0.406	0.406	NTB-12GP-S	
	7/16	0.437		7/16	0.437	0.437	NTB-13GP-S	
	1/2	0.500		1/2	0.500	0.500	NTB-14GP-S	
								NTB-16GP-S

1/2" Radius



3/4" Radius



FAST HEAT TRANSFER

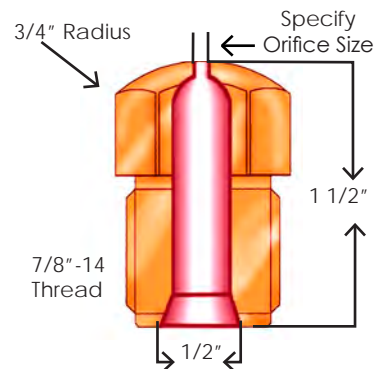
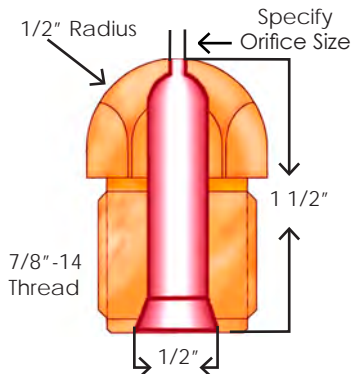

High Quality Copper Alloy								
Radius	Orifice	Part Number	Radius	Orifice	Part Number			
1/2"	1/16	0.062	3/4"	1/16	0.062	NTA-02GP-B		
	3/32	0.093		3/32	0.093	0.093	NTB-02GP-B	
	1/8	0.125		1/8	0.125	0.125	NTB-03GP-B	
	5/32	0.156		5/32	0.156	0.156	NTB-04GP-B	
	3/16	0.187		3/16	0.187	0.187	NTB-05GP-B	
	7/32	0.218		7/32	0.218	0.218	NTB-06GP-B	
	1/4	0.250		1/4	0.250	0.250	NTB-07GP-B	
	9/32	0.281		9/32	0.281	0.281	NTB-08GP-B	
	5/16	0.312		5/16	0.312	0.312	NTB-09GP-B	
	11/32	0.344		11/32	0.344	0.344	NTB-10GP-B	
	3/8	0.375		3/8	0.375	0.375	NTB-11GP-B	
	13/32	0.406		13/32	0.406	0.406	NTB-12GP-B	
	7/16	0.437		7/16	0.437	0.437	NTB-13GP-B	
	1/2	0.500		1/2	0.500	0.500	NTB-14GP-B	
								NTB-16GP-B

STANDARD NYLON REPLACEMENT NOZZLE TIP

1/2" Radius



3/4" Radius



- ◆ High Quality Steel or
- ◆ High Quality Copper Alloy
- ◆ Nylon
- ◆ Thread Size 7/8" - 14
- ◆ 1-1/2" Length O.A.
- ◆ 1/2" & 3/4" Radius

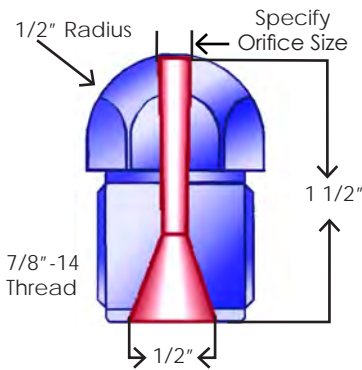

High Quality Steel					
Radius	Orifice	Part Number	Radius	Orifice	Part Number
1/2"	3/32	0.093	3/4"	3/32	0.093
	1/8	0.125		1/8	0.125
	5/32	0.156		5/32	0.156
	3/16	0.187		3/16	0.187
	1/4	0.250		1/4	0.250
	5/16	0.312		5/16	0.312
	3/8	0.375		3/8	0.375

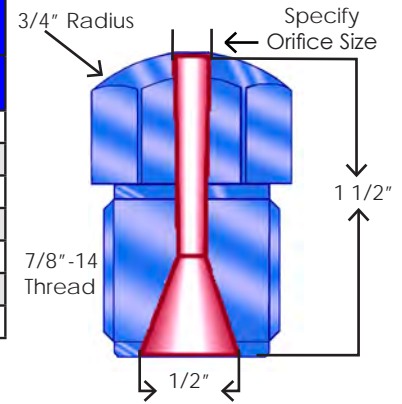

1/2" Radius



FAST HEAT TRANSFER

3/4" Radius



High Quality Copper Alloy					
Radius	Orifice	Part Number	Radius	Orifice	Part Number
1/2"	3/32	0.093	3/4"	3/32	0.093
	1/8	0.125		1/8	0.125
	5/32	0.156		5/32	0.156
	3/16	0.187		3/16	0.187
	1/4	0.250		1/4	0.250
	5/16	0.312		5/16	0.312
	3/8	0.375		3/8	0.375

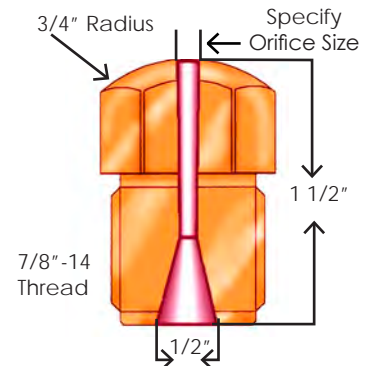
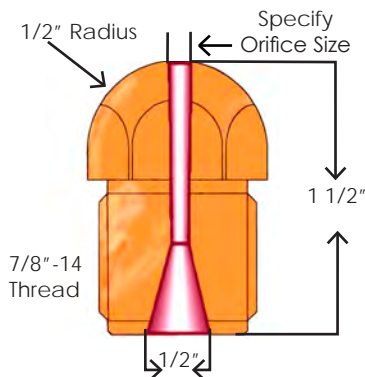

STANDARD FULL TAPER REPLACEMENT NOZZLE TIP

1/2" Radius



3/4" Radius



- ◆ High Quality Steel or
- ◆ High Quality Copper Alloy
 - ◆ Full Taper
 - ◆ Thread Size 7/8" - 14
 - ◆ 1-1/2" Length O.A.
 - ◆ 1/2" & 3/4" Radius

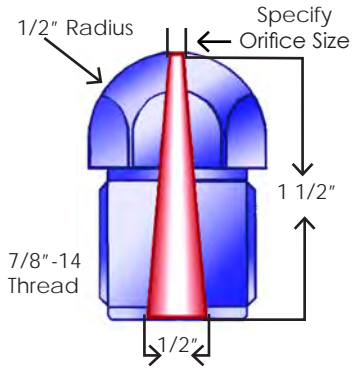

High Quality Steel						
Radius	Orifice	Part Number	Radius	Orifice	Part Number	
1/2"	3/32	0.093	3/4"	3/32	0.093	NTA-03FT-S
	1/8	0.125		1/8	0.125	NTB-04FT-S
	5/32	0.156		5/32	0.156	NTB-05FT-S
	3/16	0.187		3/16	0.187	NTB-06FT-S
	1/4	0.250		1/4	0.250	NTB-08FT-S
	5/16	0.312		5/16	0.312	NTB-10FT-S
	3/8	0.375		3/8	0.375	NTB-12FT-S

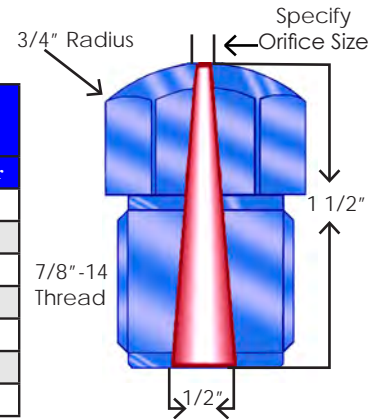

1/2" Radius



3/4" Radius



FAST HEAT TRANSFER

High Quality Copper Alloy						
Radius	Orifice	Part Number	Radius	Orifice	Part Number	
1/2"	3/32	0.093	3/4"	3/32	0.093	NTA-03FT-B
	1/8	0.125		1/8	0.125	NTB-04FT-B
	5/32	0.156		5/32	0.156	NTB-05FT-B
	3/16	0.187		3/16	0.187	NTB-06FT-B
	1/4	0.250		1/4	0.250	NTB-08FT-B
	5/16	0.312		5/16	0.312	NTB-10FT-B
	3/8	0.375		3/8	0.375	NTB-12FT-B

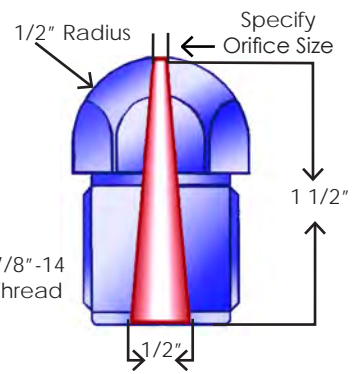
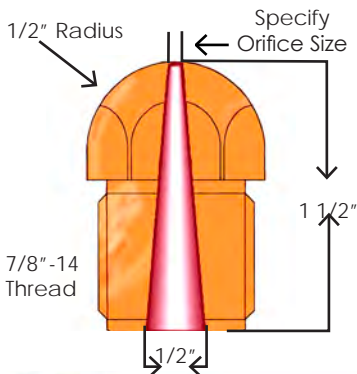

FULL RADIUS NOZZLE TIPS

- ◆ High Quality Steel
- ◆ Thread Size 7/8" - 14
- ◆ 1-1/2" Length O.A.
- ◆ 3/4" Radius



General Purpose			
Radius	Orifice		Part Number
3/4"	1/16	0.062	NTFB-02GP-S-014
	3/32	0.093	NTFB-03GP-S-014
	1/8	0.125	NTFB-04GP-S-014
	5/32	0.156	NTFB-05GP-S-014
	3/16	0.187	NTFB-06GP-S-014
	7/32	0.218	NTFB-07GP-S-014
	1/4	0.250	NTFB-08GP-S-014
	9/32	0.281	NTFB-09GP-S-014
	5/16	0.312	NTFB-10GP-S-014
	11/32	0.344	NTFB-11GP-S-014
	3/8	0.375	NTFB-12GP-S-014
	13/32	0.406	NTFB-13GP-S-014
	7/16	0.437	NTFB-14GP-S-014

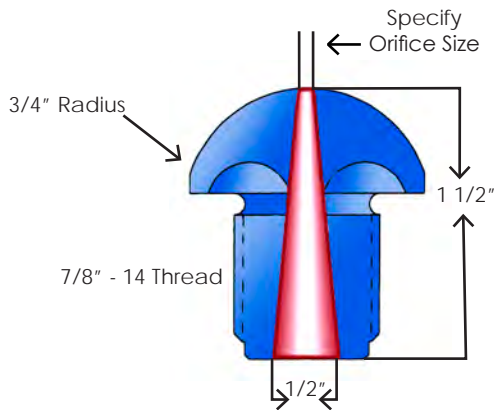
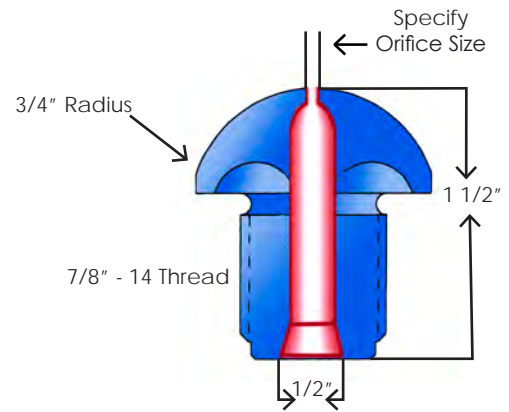

Full Taper			
Radius	Orifice		Part Number
3/4"	1/8	0.125	NTFB-04FT-S-014
	3/16	0.187	NTFB-06FT-S-014
	1/4	0.250	NTFB-08FT-S-014
	5/16	0.312	NTFB-10FT-S-014
	3/8	0.375	NTFB-12FT-S-014

Nylon			
Radius	Orifice		Part Number
3/4"	1/8	0.125	NTFB-04N-S-014
	3/16	0.187	NTFB-06N-S-014
	1/4	0.250	NTFB-08N-S-014
	5/16	0.312	NTFB-10N-S-014
	3/8	0.375	NTFB-12N-S-014

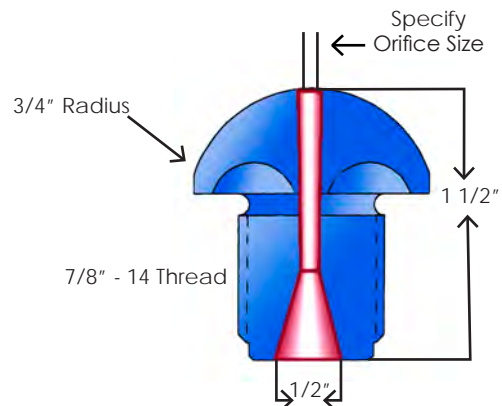

FULL RADIUS NOZZLE TIPS

- ◆ High Quality Copper Alloy
 - ◆ Thread Size 7/8" - 14
 - ◆ 1-1/2" Length O.A.
 - ◆ 3/4" Radius



FAST HEAT TRANSFER

General Purpose			
Radius	Orifice		Part Number
3/4"	1/16	0.062	NTFB-02GP-B-014
	3/32	0.093	NTFB-03GP-B-014
	1/8	0.125	NTFB-04GP-B-014
	5/32	0.156	NTFB-05GP-B-014
	3/16	0.187	NTFB-06GP-B-014
	7/32	0.218	NTFB-07GP-B-014
	1/4	0.250	NTFB-08GP-B-014
	9/32	0.281	NTFB-09GP-B-014
	5/16	0.312	NTFB-10GP-B-014
	11/32	0.344	NTFB-11GP-B-014
	3/8	0.375	NTFB-12GP-B-014
	13/32	0.406	NTFB-13GP-B-014
	7/16	0.437	NTFB-14GP-B-014

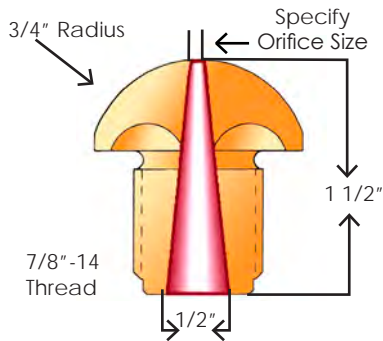
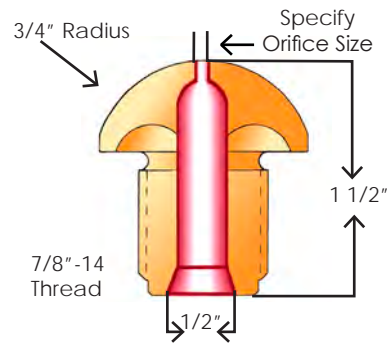

Full Taper		
Radius	Orifice	
3/4"	1/8	0.125
	3/16	0.187
	1/4	0.250
	5/16	0.312
	3/8	0.375

Nylon			
Radius	Orifice		Part Number
3/4"	1/8	0.125	NTFB-04N-B-014
	3/16	0.187	NTFB-06N-B-014
	1/4	0.250	NTFB-08N-B-014
	5/16	0.312	NTFB-10N-B-014
	3/8	0.375	NTFB-12N-B-014

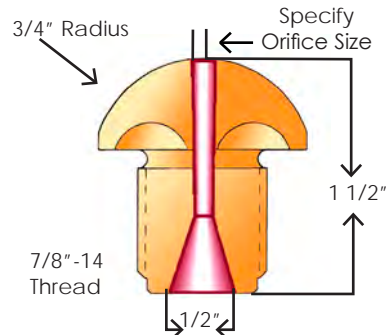

EXTENDED FULL RADIUS NOZZLE TIPS

- ◆ High Quality Steel ◆ Thread Size 7/8" - 14
- ◆ 1-3/4" Length O.A. ◆ 3/4" Radius



General Purpose			
Radius	Orifice		Part Number
3/4"	1/16	0.062	NTFB-02GP-S-016
	3/32	0.093	NTFB-03GP-S-016
	1/8	0.125	NTFB-04GP-S-016
	5/32	0.156	NTFB-05GP-S-016
	3/16	0.187	NTFB-06GP-S-016
	7/32	0.218	NTFB-07GP-S-016
	1/4	0.250	NTFB-08GP-S-016
	9/32	0.281	NTFB-09GP-S-016
	5/16	0.312	NTFB-10GP-S-016
	11/32	0.344	NTFB-11GP-S-016
	3/8	0.375	NTFB-12GP-S-016
	13/32	0.406	NTFB-13GP-S-016
	7/16	0.437	NTFB-14GP-S-016
	1/2	0.500	NTFB-16GP-S-016

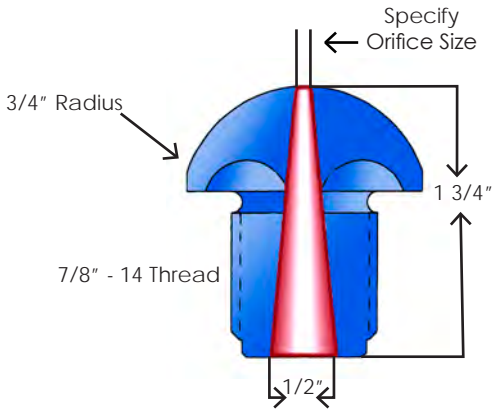
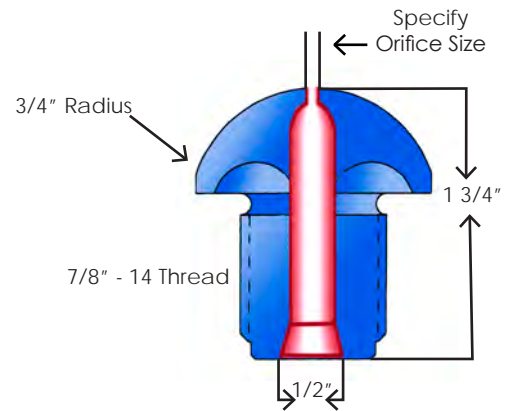

Full Taper			
Radius	Orifice		Part Number
3/4"	1/8	0.125	NTFB-04FT-S-016
	3/16	0.187	NTFB-06FT-S-016
	1/4	0.250	NTFB-08FT-S-016
	5/16	0.312	NTFB-10FT-S-016
	3/8	0.375	NTFB-12FT-S-016

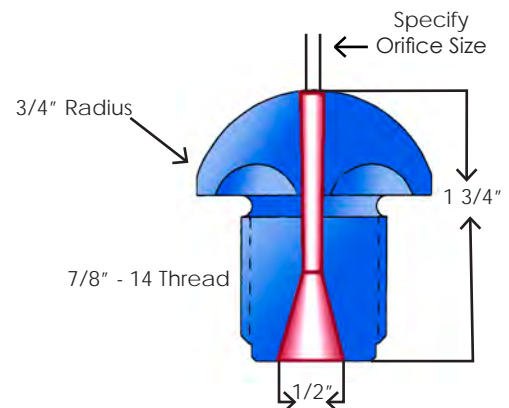

Nylon			
Radius	Orifice		Part Number
3/4"	1/8	0.125	NTFB-04N-S-016
	3/16	0.187	NTFB-06N-S-016
	1/4	0.250	NTFB-08N-S-016
	5/16	0.312	NTFB-10N-S-016
	3/8	0.375	NTFB-12N-S-016

EXTENDED FULL RADIUS NOZZLE TIPS FAST HEAT TRANSFER



- ◆ High Quality Copper Alloy ◆ Thread Size 7/8" - 14
- ◆ 1-3/4" Length O.A. ◆ 3/4" Radius

General Purpose			
Radius	Orifice		Part Number
3/4"	1/16	0.062	NTFB-02GP-B-016
	3/32	0.093	NTFB-03GP-B-016
	1/8	0.125	NTFB-04GP-B-016
	5/32	0.156	NTFB-05GP-B-016
	3/16	0.187	NTFB-06GP-B-016
	7/32	0.218	NTFB-07GP-B-016
	1/4	0.250	NTFB-08GP-B-016
	9/32	0.281	NTFB-09GP-B-016
	5/16	0.312	NTFB-10GP-B-016
	11/32	0.344	NTFB-11GP-B-016
	3/8	0.375	NTFB-12GP-B-016
	13/32	0.406	NTFB-13GP-B-016
	7/16	0.437	NTFB-14GP-B-016
	1/2	.500	NTFB-16GP-B-016

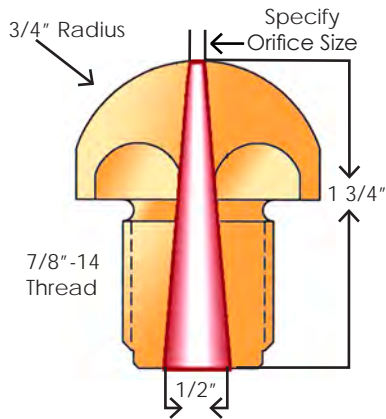
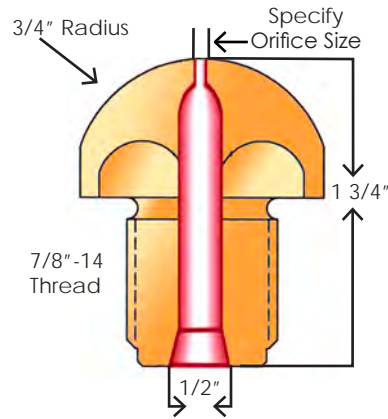

Full Taper			
Radius	Orifice		Part Number
3/4"	1/8	0.125	NTFB-04FT-B-016
	3/16	0.187	NTFB-06FT-B-016
	1/4	0.250	NTFB-08FT-B-016
	5/16	0.312	NTFB-10FT-B-016
	3/8	0.375	NTFB-12FT-B-016

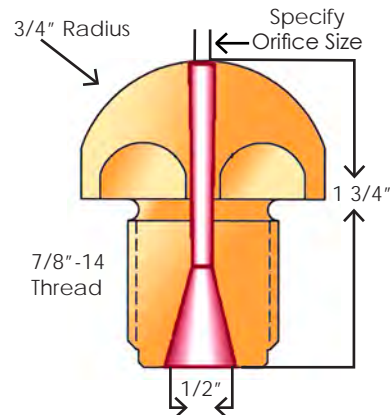

Nylon			
Radius	Orifice		Part Number
3/4"	1/8	0.125	NTFB-04N-B-016
	3/16	0.187	NTFB-06N-B-016
	1/4	0.250	NTFB-08N-B-016
	5/16	0.312	NTFB-10N-B-016
	3/8	0.375	NTFB-12N-B-016
	1/2	0.500	NTFB-16N-B-016

2 1/2" EXTENDED FULL RADIUS NOZZLE TIPS



- ◆ High Quality Steel
- ◆ High Quality Copper Alloy
 - ◆ General Purpose
 - ◆ Thread Size 7/8" - 14
 - ◆ 2-1/2" Length O.A.
 - ◆ 3/4" Radius

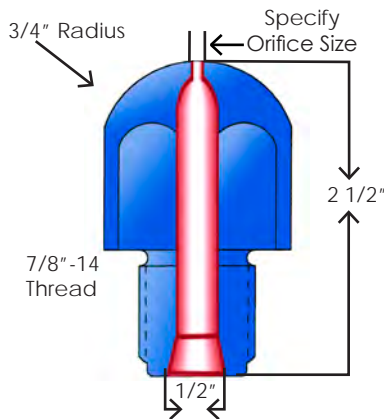

High Quality Steel			
Radius	Orifice		Part Number
3/4"	1/16	0.062	NTFB-02GP-S-024
	3/32	0.093	NTFB-03GP-S-024
	1/8	0.125	NTFB-04GP-S-024
	5/32	0.156	NTFB-05GP-S-024
	3/16	0.187	NTFB-06GP-S-024
	7/32	0.218	NTFB-07GP-S-024
	1/4	0.250	NTFB-08GP-S-024
	9/32	0.281	NTFB-09GP-S-024
	5/16	0.312	NTFB-10GP-S-024
	11/32	0.344	NTFB-11GP-S-024
	3/8	0.375	NTFB-12GP-S-024
	13/32	0.406	NTFB-13GP-S-024
	7/16	0.437	NTFB-14GP-S-024
	1/2	.500	NTFB-16GP-S-024

FAST HEAT TRANSFER

High Quality Copper Alloy			
Radius	Orifice		Part Number
3/4"	1/16	0.062	NTFB-02GP-B-024
	3/32	0.093	NTFB-03GP-B-024
	1/8	0.125	NTFB-04GP-B-024
	5/32	0.156	NTFB-05GP-B-024
	3/16	0.187	NTFB-06GP-B-024
	7/32	0.218	NTFB-07GP-B-024
	1/4	0.250	NTFB-08GP-B-024
	9/32	0.281	NTFB-09GP-B-024
	5/16	0.312	NTFB-10GP-B-024
	11/32	0.344	NTFB-11GP-B-024
	3/8	0.375	NTFB-12GP-B-024
	13/32	0.406	NTFB-13GP-B-024
	7/16	0.437	NTFB-14GP-B-024
	1/2	.500	NTFB-16GP-B-024

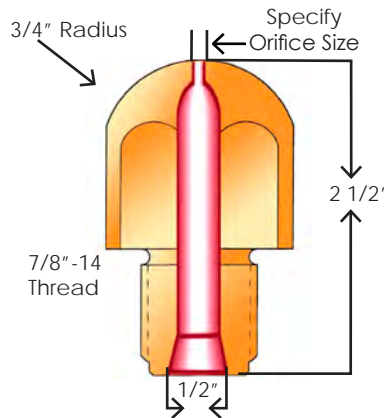

2 3/4" EXTENDED TIPS GENERAL PURPOSE



- ◆ High Quality Steel
- ◆ High Quality Copper Alloy
- ◆ General Purpose
 - ◆ Thread Size 7/8" - 14
 - ◆ 2-3/4" Length O.A.
 - ◆ 1/2" & 3/4" Radius
 - ◆ 1" O.D.
- ◆ Requires 1" x 1" Heater



High Quality Steel							
Radius	Orifice	Part Number	Radius	Orifice	Part Number		
1/2"	1/16	0.062	NTEA-02GP-S-026	3/4"	1/16	0.062	NTEB-02GP-S-026
	3/32	0.093	NTEA-03GP-S-026		3/32	0.093	NTEB-03GP-S-026
	1/8	0.125	NTEA-04GP-S-026		1/8	0.125	NTEB-04GP-S-026
	5/32	0.156	NTEA-05GP-S-026		5/32	0.156	NTEB-05GP-S-026
	3/16	0.187	NTEA-06GP-S-026		3/16	0.187	NTEB-06GP-S-026
	7/32	0.218	NTEA-07GP-S-026		7/32	0.218	NTEB-07GP-S-026
	1/4	0.250	NTEA-08GP-S-026		1/4	0.250	NTEB-08GP-S-026
	9/32	0.281	NTEA-09GP-S-026		9/32	0.281	NTEB-09GP-S-026
	5/16	0.312	NTEA-10GP-S-026		5/16	0.312	NTEB-10GP-S-026
	11/32	0.344	NTEA-11GP-S-026		11/32	0.344	NTEB-11GP-S-026
	3/8	0.375	NTEA-12GP-S-026		3/8	0.375	NTEB-12GP-S-026
	13/32	0.406	NTEA-13GP-S-026		13/32	0.406	NTEB-13GP-S-026
	7/16	0.437	NTEA-14GP-S-026		7/16	0.437	NTEB-14GP-S-026
	1/2	0.500	NTEA-16GP-S-026		1/2	0.500	NTEB-16GP-S-026

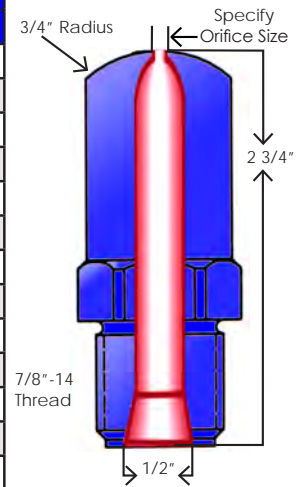
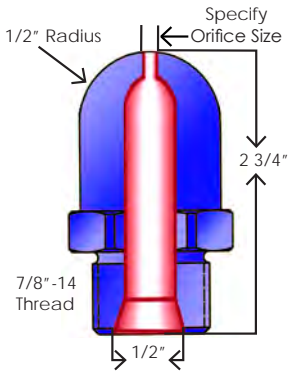

FAST HEAT TRANSFER

High Quality Copper Alloy							
Radius	Orifice	Part Number	Radius	Orifice	Part Number		
1/2"	1/16	0.062	NTEA-02GP-B-026	3/4"	1/16	0.062	NTEB-02GP-B-026
	3/32	0.093	NTEA-03GP-B-026		3/32	0.093	NTEB-03GP-B-026
	1/8	0.125	NTEA-04GP-B-026		1/8	0.125	NTEB-04GP-B-026
	5/32	0.156	NTEA-05GP-B-026		5/32	0.156	NTEB-05GP-B-026
	3/16	0.187	NTEA-06GP-B-026		3/16	0.187	NTEB-06GP-B-026
	7/32	0.218	NTEA-07GP-B-026		7/32	0.218	NTEB-07GP-B-026
	1/4	0.250	NTEA-08GP-B-026		1/4	0.250	NTEB-08GP-B-026
	9/32	0.281	NTEA-09GP-B-026		9/32	0.281	NTEB-09GP-B-026
	5/16	0.312	NTEA-10GP-B-026		5/16	0.312	NTEB-10GP-B-026
	11/32	0.344	NTEA-11GP-B-026		11/32	0.344	NTEB-11GP-B-026
	3/8	0.375	NTEA-12GP-B-026		3/8	0.375	NTEB-12GP-B-026
	13/32	0.406	NTEA-13GP-B-026		13/32	0.406	NTEB-13GP-B-026
	7/16	0.437	NTEA-14GP-B-026		7/16	0.437	NTEB-14GP-B-026
	1/2	0.500	NTEA-16GP-B-026		1/2	0.500	NTEB-16GP-B-026

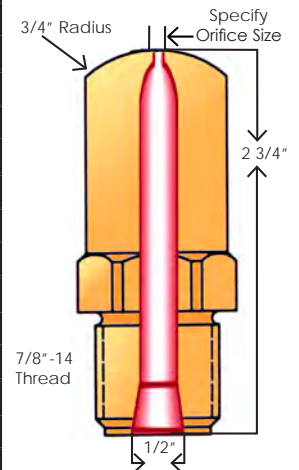
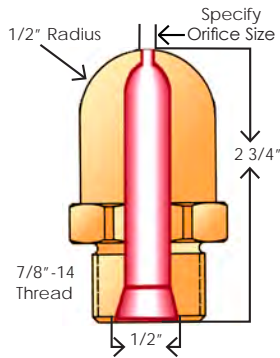

2 3/4" EXTENDED TIPS NYLON



- ◆ High Quality Steel
- ◆ High Quality Copper Alloy
- ◆ Nylon
 - ◆ Thread Size 7/8" - 14
 - ◆ 2-3/4" Length O.A.
 - ◆ 1/2" & 3/4" Radius
 - ◆ 1" O.D.
- ◆ Requires 1" x 1" Heater

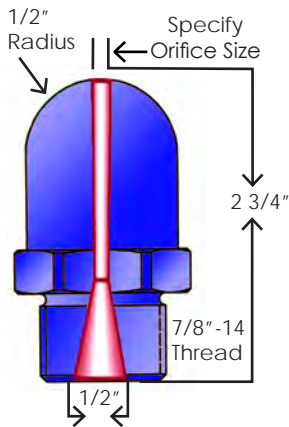

High Quality Steel							
Radius	Orifice	Part Number	Radius	Orifice	Part Number		
1/2"	1/8	0.125	NTEA-04N-S-026	3/4"	1/8	0.125	NTEB-04N-S-026
	5/32	0.156	NTEA-05N-S-026		5/32	0.156	NTEB-05N-S-026
	3/16	0.187	NTEA-06N-S-026		3/16	0.187	NTEB-06N-S-026
	1/4	0.250	NTEA-08N-S-026		1/4	0.250	NTEB-08N-S-026
	5/16	0.312	NTEA-10N-S-026		5/16	0.312	NTEB-10N-S-026
	3/8	0.375	NTEA-12N-S-026		3/8	0.375	NTEB-12N-S-026

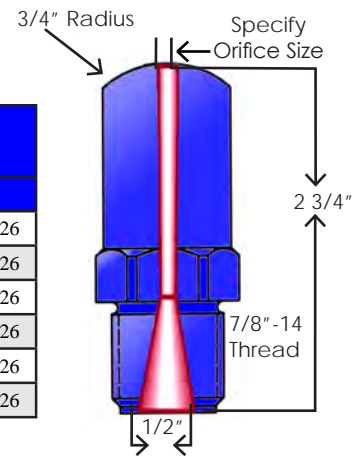

FAST HEAT TRANSFER

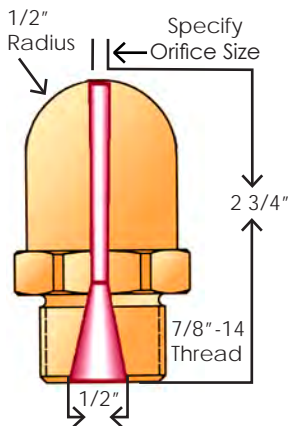

High Quality Copper Alloy							
Radius	Orifice	Part Number	Radius	Orifice	Part Number		
1/2"	1/8	0.125	NTEA-04N-B-026	3/4"	1/8	0.125	NTEB-04N-B-026
	5/32	0.156	NTEA-05N-B-026		5/32	0.156	NTEB-05N-B-026
	3/16	0.187	NTEA-06N-B-026		3/16	0.187	NTEB-06N-B-026
	1/4	0.250	NTEA-08N-B-026		1/4	0.250	NTEB-08N-B-026
	5/16	0.312	NTEA-10N-B-026		5/16	0.312	NTEB-10N-B-026
	3/8	0.375	NTEA-12N-B-026		3/8	0.375	NTEB-12N-B-026

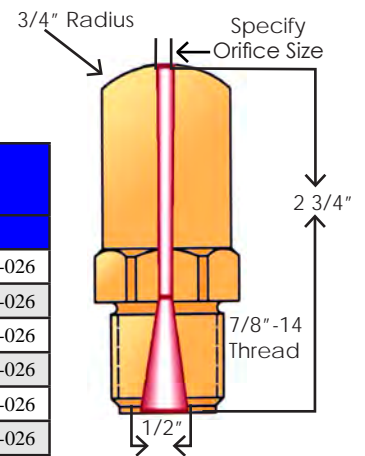

3 1/4" EXTENDED TIPS

- ◆ High Quality Steel
- ◆ High Quality Copper Alloy
- ◆ General Purpose
 - ◆ Thread Size 7/8" - 14
 - ◆ 3 1/4" Length O.A.
 - ◆ 1/2" & 3/4" Radius
 - ◆ 1" O.D.
- ◆ Requires 1" x 1-1/2" Heater

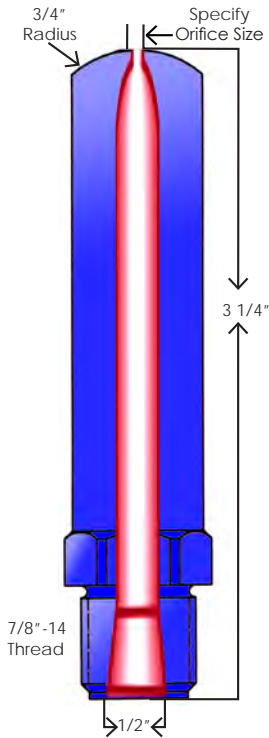

High Quality Steel						
Radius	Orifice	Part Number	Radius	Orifice	Part Number	
1/2"	1/16	0.062	3/4"	1/16	0.062	NTEA-02GP-S-032
	3/32	0.093		3/32	0.093	NTEB-03GP-S-032
	1/8	0.125		1/8	0.125	NTEB-04GP-S-032
	5/32	0.156		5/32	0.156	NTEB-05GP-S-032
	3/16	0.187		3/16	0.187	NTEB-06GP-S-032
	7/32	0.218		7/32	0.218	NTEB-07GP-S-032
	1/4	0.250		1/4	0.250	NTEB-08GP-S-032
	9/32	0.281		9/32	0.281	NTEB-09GP-S-032
	5/16	0.312		5/16	0.312	NTEB-10GP-S-032
	11/32	0.344		11/32	0.344	NTEB-11GP-S-032
	3/8	0.375		3/8	0.375	NTEB-12GP-S-032
	13/32	0.406		13/32	0.406	NTEB-13GP-S-032
	7/16	0.437		7/16	0.437	NTEB-14GP-S-032
	1/2	0.500		1/2	0.500	NTEB-16GP-S-032

FAST HEAT TRANSFER

High Quality Copper Alloy						
Radius	Orifice	Part Number	Radius	Orifice	Part Number	
1/2"	1/16	0.062	3/4"	1/16	0.062	NTEA-02GP-B-032
	3/32	0.093		3/32	0.093	NTEB-03GP-B-032
	1/8	0.125		1/8	0.125	NTEB-04GP-B-032
	5/32	0.156		5/32	0.156	NTEB-05GP-B-032
	3/16	0.187		3/16	0.187	NTEB-06GP-B-032
	7/32	0.218		7/32	0.218	NTEB-07GP-B-032
	1/4	0.250		1/4	0.250	NTEB-08GP-B-032
	9/32	0.281		9/32	0.281	NTEB-09GP-B-032
	5/16	0.312		5/16	0.312	NTEB-10GP-B-032
	11/32	0.344		11/32	0.344	NTEB-11GP-B-032
	3/8	0.375		3/8	0.375	NTEB-12GP-B-032
	13/32	0.406		13/32	0.406	NTEB-13GP-B-032
	7/16	0.437		7/16	0.437	NTEB-14GP-B-032
	1/2	0.500		1/2	0.500	NTEB-16GP-B-032

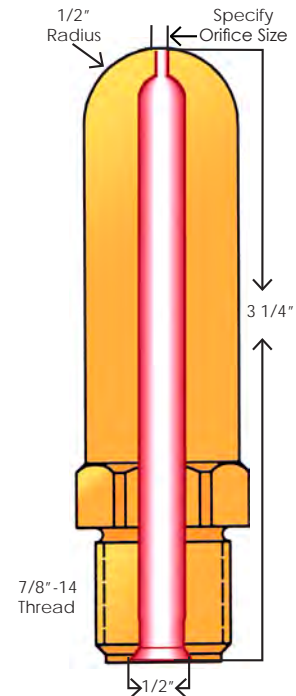

4" EXTENDED TIPS

- ◆ High Quality Steel
- ◆ High Quality Copper Alloy
 - ◆ General Purpose
 - ◆ Thread Size 7/8" - 14
 - ◆ 4" Length O.A.
 - ◆ 1/2" & 3/4" Radius
 - ◆ 1" O.D.
- ◆ Requires 1" x 2" Heater

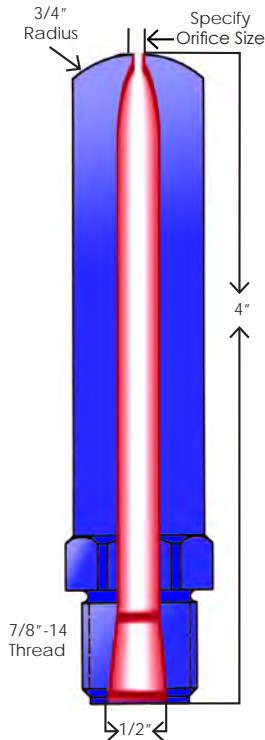
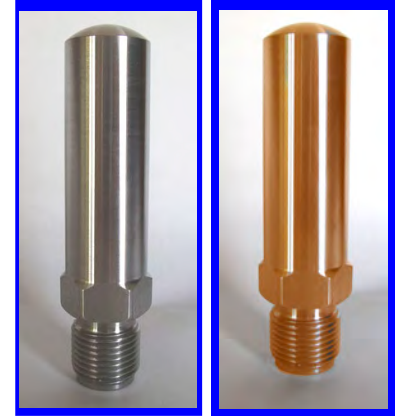

High Quality Steel							
Radius	Orifice		Part Number	Radius	Orifice		Part Number
1/2"	1/16	0.062	NTEA-02GP-S-040	3/4"	1/16	0.062	NTEB-02GP-S-040
	3/32	0.093	NTEA-03GP-S-040		3/32	0.093	NTEB-03GP-S-040
	1/8	0.125	NTEA-04GP-S-040		1/8	0.125	NTEB-04GP-S-040
	5/32	0.156	NTEA-05GP-S-040		5/32	0.156	NTEB-05GP-S-040
	3/16	0.187	NTEA-06GP-S-040		3/16	0.187	NTEB-06GP-S-040
	7/32	0.218	NTEA-07GP-S-040		7/32	0.218	NTEB-07GP-S-040
	1/4	0.250	NTEA-08GP-S-040		1/4	0.250	NTEB-08GP-S-040
	9/32	0.281	NTEA-09GP-S-040		9/32	0.281	NTEB-09GP-S-040
	5/16	0.312	NTEA-10GP-S-040		5/16	0.312	NTEB-10GP-S-040
	11/32	0.344	NTEA-11GP-S-040		11/32	0.344	NTEB-11GP-S-040
	3/8	0.375	NTEA-12GP-S-040		3/8	0.375	NTEB-12GP-S-040
	13/32	0.406	NTEA-13GP-S-040		13/32	0.406	NTEB-13GP-S-040
	7/16	0.437	NTEA-14GP-S-040		7/16	0.437	NTEB-14GP-S-040
	1/2	0.500	NTEA-16GP-S-040		1/2	0.500	NTEB-16GP-S-040

FAST HEAT TRANSFER

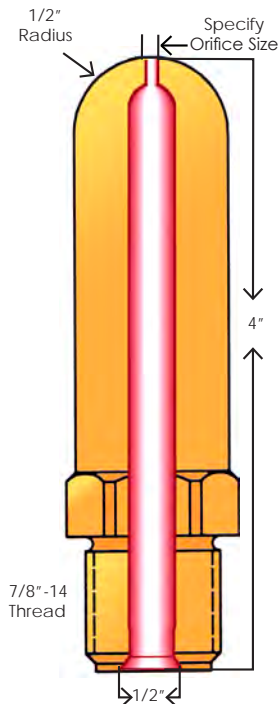

High Quality Copper Alloy							
Radius	Orifice		Part Number	Radius	Orifice		Part Number
1/2"	1/16	0.062	NTEA-02GP-B-040	3/4"	1/16	0.062	NTEB-02GP-B-040
	3/32	0.093	NTEA-03GP-B-040		3/32	0.093	NTEB-03GP-B-040
	1/8	0.125	NTEA-04GP-B-040		1/8	0.125	NTEB-04GP-B-040
	5/32	0.156	NTEA-05GP-B-040		5/32	0.156	NTEB-05GP-B-040
	3/16	0.187	NTEA-06GP-B-040		3/16	0.187	NTEB-06GP-B-040
	7/32	0.218	NTEA-07GP-B-040		7/32	0.218	NTEB-07GP-B-040
	1/4	0.250	NTEA-08GP-B-040		1/4	0.250	NTEB-08GP-B-040
	9/32	0.281	NTEA-09GP-B-040		9/32	0.281	NTEB-09GP-B-040
	5/16	0.312	NTEA-10GP-B-040		5/16	0.312	NTEB-10GP-B-040
	11/32	0.344	NTEA-11GP-B-040		11/32	0.344	NTEB-11GP-B-040
	3/8	0.375	NTEA-12GP-B-040		3/8	0.375	NTEB-12GP-B-040
	13/32	0.406	NTEA-13GP-B-040		13/32	0.406	NTEB-13GP-B-040
	7/16	0.437	NTEA-14GP-B-040		7/16	0.437	NTEB-14GP-B-040
	1/2	0.500	NTEA-16GP-B-040		1/2	0.500	NTEB-16GP-B-040

5" EXTENDED TIPS

- ◆ High Quality Steel
 - ◆ General Purpose
 - ◆ 5" Length O.A.
 - ◆ Thread Size 7/8" - 14
 - ◆ 1/2" & 3/4" Radius
 - ◆ 1" O.D.
- ◆ Requires 1" x 3" Heater

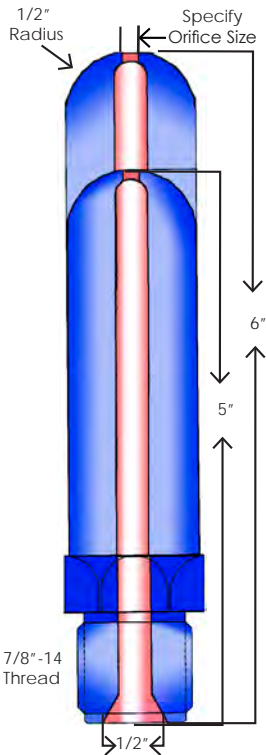

5" Extended Tip Length			
Radius	Orifice		Part Number
1/2"	1/16	0.062	NTEA-02GP-S-050
	3/32	0.093	NTEA-03GP-S-050
	1/8	0.125	NTEA-04GP-S-050
	5/32	0.156	NTEA-05GP-S-050
	3/16	0.187	NTEA-06GP-S-050
	7/32	0.218	NTEA-07GP-S-050
	1/4	0.250	NTEA-08GP-S-050
	9/32	0.281	NTEA-09GP-S-050
	5/16	0.312	NTEA-10GP-S-050
	11/32	0.344	NTEA-11GP-S-050
	3/8	0.375	NTEA-12GP-S-050
	13/32	0.406	NTEA-13GP-S-050
	7/16	0.437	NTEA-14GP-S-050
	1/2	.500	NTEA-16GP-S-050

5" Extended Tip Length			
Radius	Orifice		Part Number
3/4"	1/16	0.062	NTEB-02GP-S-050
	3/32	0.093	NTEB-03GP-S-050
	1/8	0.125	NTEB-04GP-S-050
	5/32	0.156	NTEB-05GP-S-050
	3/16	0.187	NTEB-06GP-S-050
	7/32	0.218	NTEB-07GP-S-050
	1/4	0.250	NTEB-08GP-S-050
	9/32	0.281	NTEB-09GP-S-050
	5/16	0.312	NTEB-10GP-S-050
	11/32	0.344	NTEB-11GP-S-050
	3/8	0.375	NTEB-12GP-S-050
	13/32	0.406	NTEB-13GP-S-050
	7/16	0.437	NTEB-14GP-S-050
	1/2	.500	NTEB-16GP-S-050

6" EXTENDED TIPS

- ◆ High Quality Steel
 - ◆ General Purpose
 - ◆ 6" Length O.A.
 - ◆ Thread Size 7/8" - 14
 - ◆ 1/2" & 3/4" Radius
 - ◆ 1" O.D.
- ◆ Requires 1" x 4" Heater

6" Extended Tip Length			
Radius	Orifice		Part Number
1/2"	1/16	0.062	NTEA-02GP-S-060
	3/32	0.093	NTEA-03GP-S-060
	1/8	0.125	NTEA-04GP-S-060
	5/32	0.156	NTEA-05GP-S-060
	3/16	0.187	NTEA-06GP-S-060
	7/32	0.218	NTEA-07GP-S-060
	1/4	0.250	NTEA-08GP-S-060
	9/32	0.281	NTEA-09GP-S-060
	5/16	0.312	NTEA-10GP-S-060
	11/32	0.344	NTEA-11GP-S-060
	3/8	0.375	NTEA-12GP-S-060
	13/32	0.406	NTEA-13GP-S-060
	7/16	0.437	NTEA-14GP-S-060
	1/2	.500	NTEA-16GP-S-060

6" Extended Tip Length			
Radius	Orifice		Part Number
3/4"	1/16	0.062	NTEB-02GP-S-060
	3/32	0.093	NTEB-03GP-S-060
	1/8	0.125	NTEB-04GP-S-060
	5/32	0.156	NTEB-05GP-S-060
	3/16	0.187	NTEB-06GP-S-060
	7/32	0.218	NTEB-07GP-S-060
	1/4	0.250	NTEB-08GP-S-060
	9/32	0.281	NTEB-09GP-S-060
	5/16	0.312	NTEB-10GP-S-060
	11/32	0.344	NTEB-11GP-S-060
	3/8	0.375	NTEB-12GP-S-060
	13/32	0.406	NTEB-13GP-S-060
	7/16	0.437	NTEB-14GP-S-060
	1/2	.500	NTEB-16GP-S-060

7" EXTENDED TIPS

- ◆ High Quality Steel
 - ◆ General Purpose
 - ◆ 7" Length O.A.
 - ◆ Thread Size 7/8" - 14
 - ◆ 1/2" & 3/4" Radius
 - ◆ 1" O.D.
- ◆ Requires 1" x 5" Heater

7" Extended Tip Length			
Radius	Orifice		Part Number
1/2"	1/16	0.062	NTEA-02GP-S-070
	3/32	0.093	NTEA-03GP-S-070
	1/8	0.125	NTEA-04GP-S-070
	5/32	0.156	NTEA-05GP-S-070
	3/16	0.187	NTEA-06GP-S-070
	7/32	0.218	NTEA-07GP-S-070
	1/4	0.250	NTEA-08GP-S-070
	9/32	0.281	NTEA-09GP-S-070
	5/16	0.312	NTEA-10GP-S-070
	11/32	0.344	NTEA-11GP-S-070
	3/8	0.375	NTEA-12GP-S-070
	13/32	0.406	NTEA-13GP-S-070
	7/16	0.437	NTEA-14GP-S-070
	1/2	.500	NTEA-16GP-S-070

7" Extended Tip Length			
Radius	Orifice		Part Number
3/4"	1/16	0.062	NTEB-02GP-S-070
	3/32	0.093	NTEB-03GP-S-070
	1/8	0.125	NTEB-04GP-S-070
	5/32	0.156	NTEB-05GP-S-070
	3/16	0.187	NTEB-06GP-S-070
	7/32	0.218	NTEB-07GP-S-070
	1/4	0.250	NTEB-08GP-S-070
	9/32	0.281	NTEB-09GP-S-070
	5/16	0.312	NTEB-10GP-S-070
	11/32	0.344	NTEB-11GP-S-070
	3/8	0.375	NTEB-12GP-S-070
	13/32	0.406	NTEB-13GP-S-070
	7/16	0.437	NTEB-14GP-S-070
	1/2	.500	NTEB-16GP-S-070

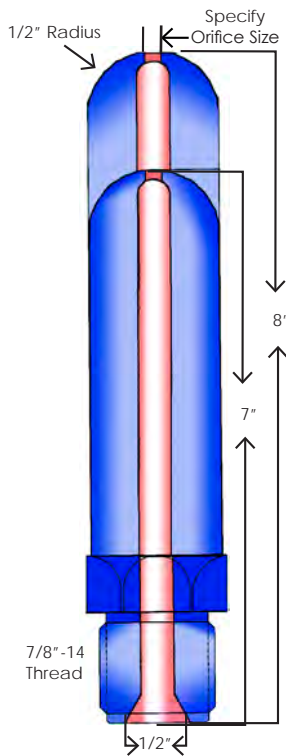

8" EXTENDED TIPS

- ◆ High Quality Steel
 - ◆ General Purpose
 - ◆ 8" Length O.A.
 - ◆ Thread Size 7/8" - 14
 - ◆ 1/2" & 3/4" Radius
 - ◆ 1" O.D.
- ◆ Requires 1" x 6" Heater

8" Extended Tip Length			
Radius	Orifice		Part Number
1/2"	1/16	0.062	NTEA-02GP-S-080
	3/32	0.093	NTEA-03GP-S-080
	1/8	0.125	NTEA-04GP-S-080
	5/32	0.156	NTEA-05GP-S-080
	3/16	0.187	NTEA-06GP-S-080
	7/32	0.218	NTEA-07GP-S-080
	1/4	0.250	NTEA-08GP-S-080
	9/32	0.281	NTEA-09GP-S-080
	5/16	0.312	NTEA-10GP-S-080
	11/32	0.344	NTEA-11GP-S-080
	3/8	0.375	NTEA-12GP-S-080
	13/32	0.406	NTEA-13GP-S-080
	7/16	0.437	NTEA-14GP-S-080
	1/2	.500	NTEA-16GP-S-080

8" Extended Tip Length			
Radius	Orifice		Part Number
3/4"	1/16	0.062	NTEB-02GP-S-080
	3/32	0.093	NTEB-03GP-S-080
	1/8	0.125	NTEB-04GP-S-080
	5/32	0.156	NTEB-05GP-S-080
	3/16	0.187	NTEB-06GP-S-080
	7/32	0.218	NTEB-07GP-S-080
	1/4	0.250	NTEB-08GP-S-080
	9/32	0.281	NTEB-09GP-S-080
	5/16	0.312	NTEB-10GP-S-080
	11/32	0.344	NTEB-11GP-S-080
	3/8	0.375	NTEB-12GP-S-080
	13/32	0.406	NTEB-13GP-S-080
	7/16	0.437	NTEB-14GP-S-080
	1/2	.500	NTEB-16GP-S-080

BIG REPLACEMENT NOZZLE TIPS



- ◆ High Quality Steel or
- ◆ High Quality Copper Alloy
- ◆ General Purpose
- ◆ Thread Size 1 1/4" - 12
- ◆ 1-5/8" Length O.A.
- ◆ 1/2" & 3/4" Radius

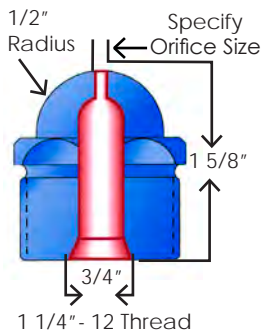

High Quality Steel			
Radius	Orifice	Part Number	
1/2"	1/16	0.062	NTFA-02GP-S1-014
	3/32	0.093	NTFA-03GP-S1-014
	1/8	0.125	NTFA-04GP-S1-014
	5/32	0.156	NTFA-05GP-S1-014
	3/16	0.187	NTFA-06GP-S1-014
	7/32	0.218	NTFA-07GP-S1-014
	1/4	0.250	NTFA-08GP-S1-014
	9/32	0.281	NTFA-09GP-S1-014
	5/16	0.312	NTFA-10GP-S1-014
	11/32	0.344	NTFA-11GP-S1-014
	3/8	0.375	NTFA-12GP-S1-014
	13/32	0.406	NTFA-13GP-S1-014
	7/16	0.437	NTFA-14GP-S1-014
	1/2	0.500	NTFA-16GP-S1-014
	9/16	0.563	NTFA-18GP-S1-014
	5/8	0.625	NTFA-20GP-S1-014
	11/16	0.688	NTFA-22GP-S1-014
	3/4	0.750	NTFA-24GP-S1-014

High Quality Copper Alloy			
Orifice	Part Number		
1/16	0.062	NTFA-02GP-B1-014	
3/32	0.093	NTFA-03GP-B1-014	
1/8	0.125	NTFA-04GP-B1-014	
5/32	0.156	NTFA-05GP-B1-014	
3/16	0.187	NTFA-06GP-B1-014	
7/32	0.218	NTFA-07GP-B1-014	
1/4	0.250	NTFA-08GP-B1-014	
9/32	0.281	NTFA-09GP-B1-014	
5/16	0.312	NTFA-10GP-B1-014	
11/32	0.344	NTFA-11GP-B1-014	
3/8	0.375	NTFA-12GP-B1-014	
13/32	0.406	NTFA-13GP-B1-014	
7/16	0.437	NTFA-14GP-B1-014	
1/2	0.500	NTFA-16GP-B1-014	
9/16	0.563	NTFA-18GP-B1-014	
5/8	0.625	NTFA-20GP-B1-014	
11/16	0.688	NTFA-22GP-B1-014	
3/4	0.750	NTFA-24GP-B1-014	

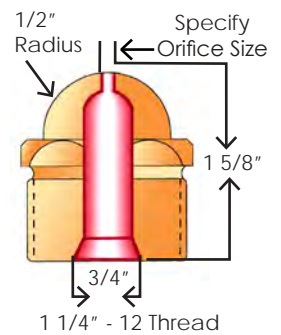

High Quality Steel			
Radius	Orifice	Part Number	
3/4"	1/16	0.062	NTFB-02GP-S1-014
	3/32	0.093	NTFB-03GP-S1-014
	1/8	0.125	NTFB-04GP-S1-014
	5/32	0.156	NTFB-05GP-S1-014
	3/16	0.187	NTFB-06GP-S1-014
	7/32	0.218	NTFB-07GP-S1-014
	1/4	0.250	NTFB-08GP-S1-014
	9/32	0.281	NTFB-09GP-S1-014
	5/16	0.312	NTFB-10GP-S1-014
	11/32	0.344	NTFB-11GP-S1-014
	3/8	0.375	NTFB-12GP-S1-014
	13/32	0.406	NTFB-13GP-S1-014
	7/16	0.437	NTFB-14GP-S1-014
	1/2	0.500	NTFB-16GP-S1-014
	9/16	0.563	NTFB-18GP-S1-014
	5/8	0.625	NTFB-20GP-S1-014
	11/16	0.688	NTFB-22GP-S1-014
	3/4	0.750	NTFB-24GP-S1-014

High Quality Copper Alloy			
Orifice	Part Number		
1/16	0.062	NTFB-02GP-B1-014	
3/32	0.093	NTFB-03GP-B1-014	
1/8	0.125	NTFB-04GP-B1-014	
5/32	0.156	NTFB-05GP-B1-014	
3/16	0.187	NTFB-06GP-B1-014	
7/32	0.218	NTFB-07GP-B1-014	
1/4	0.250	NTFB-08GP-B1-014	
9/32	0.281	NTFB-09GP-B1-014	
5/16	0.312	NTFB-10GP-B1-014	
11/32	0.344	NTFB-11GP-B1-014	
3/8	0.375	NTFB-12GP-B1-014	
13/32	0.406	NTFB-13GP-B1-014	
7/16	0.437	NTFB-14GP-B1-014	
1/2	0.500	NTFB-16GP-B1-014	
9/16	0.563	NTFB-18GP-B1-014	
5/8	0.625	NTFB-20GP-B1-014	
11/16	0.688	NTFB-22GP-B1-014	
3/4	0.750	NTFB-24GP-B1-014	

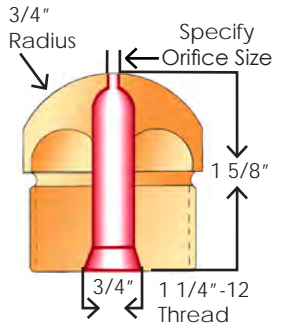
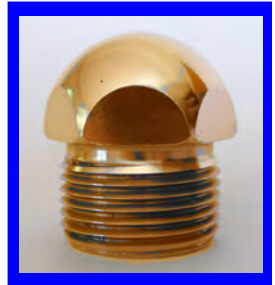
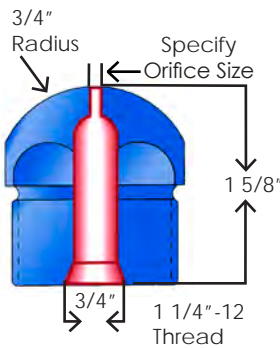

BIG REPLACEABLE NOZZLE TIPS



- ◆ Full Taper
- ◆ High Quality Steel
- ◆ High Quality Copper Alloy
- ◆ Thread Size 1 1/4" - 12
- ◆ 1 5/8" Length O.A.
- ◆ 1/2" & 3/4" Radius



1/2" Radius

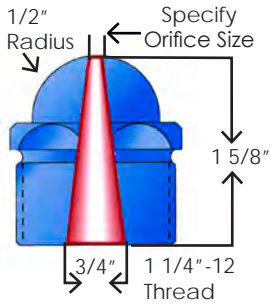

High Quality Steel			
Radius	Orifice		Part Number
1/2"	1/16	0.062	NTFA-02FT-S1-014
	3/32	0.093	NTFA-03FT-S1-014
	1/8	0.125	NTFA-04FT-S1-014
	5/32	0.156	NTFA-05FT-S1-014
	3/16	0.187	NTFA-06FT-S1-014
	7/32	0.218	NTFA-07FT-S1-014
	1/4	0.250	NTFA-08FT-S1-014
	9/32	0.281	NTFA-09FT-S1-014
	5/16	0.312	NTFA-10FT-S1-014
	11/32	0.344	NTFA-11FT-S1-014
	3/8	0.375	NTFA-12FT-S1-014
	13/32	0.406	NTFA-13FT-S1-014
	7/16	0.437	NTFA-14FT-S1-014
	1/2	0.500	NTFA-16FT-S1-014
	9/16	0.563	NTFA-18FT-S1-014
	5/8	0.625	NTFA-20FT-S1-014
11/16	0.688	NTFA-22FT-S1-014	
3/4	0.750	NTFA-24FT-S1-014	

High Quality Copper Alloy			
Orifice		Part Number	
1/16	0.062	NTFA-02FT-B1-014	
3/32	0.093	NTFA-03FT-B1-014	
1/8	0.125	NTFA-04FT-B1-014	
5/32	0.156	NTFA-05FT-B1-014	
3/16	0.187	NTFA-06FT-B1-014	
7/32	0.218	NTFA-07FT-B1-014	
1/4	0.250	NTFA-08FT-B1-014	
9/32	0.281	NTFA-09FT-B1-014	
5/16	0.312	NTFA-10FT-B1-014	
11/32	0.344	NTFA-11FT-B1-014	
3/8	0.375	NTFA-12FT-B1-014	
13/32	0.406	NTFA-13FT-B1-014	
7/16	0.437	NTFA-14FT-B1-014	
1/2	0.500	NTFA-16FT-B1-014	
9/16	0.563	NTFA-18FT-B1-014	
5/8	0.625	NTFA-20FT-B1-014	
11/16	0.688	NTFA-22FT-B1-014	
3/4	0.750	NTFA-24FT-B1-014	

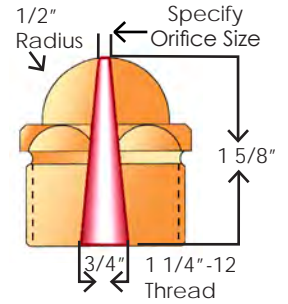

3/4" Radius

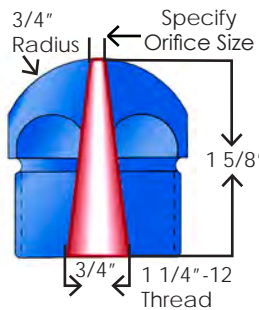

High Quality Steel			
Radius	Orifice		Part Number
3/4"	1/16	0.062	NTFB-02FT-S1-014
	3/32	0.093	NTFB-03FT-S1-014
	1/8	0.125	NTFB-04FT-S1-014
	5/32	0.156	NTFB-05FT-S1-014
	3/16	0.187	NTFB-06FT-S1-014
	7/32	0.218	NTFB-07FT-S1-014
	1/4	0.250	NTFB-08FT-S1-014
	9/32	0.281	NTFB-09FT-S1-014
	5/16	0.312	NTFB-10FT-S1-014
	11/32	0.344	NTFB-11FT-S1-014
	3/8	0.375	NTFB-12FT-S1-014
	13/32	0.406	NTFB-13FT-S1-014
	7/16	0.437	NTFB-14FT-S1-014
	1/2	0.500	NTFB-16FT-S1-014
	9/16	0.563	NTFB-18FT-S1-014
	5/8	0.625	NTFB-20FT-S1-014
11/16	0.688	NTFB-22FT-S1-014	
3/4	0.750	NTFB-24FT-S1-014	

High Quality Copper Alloy			
Orifice		Part Number	
1/16	0.062	NTFB-02FT-B1-014	
3/32	0.093	NTFB-03FT-B1-014	
1/8	0.125	NTFB-04FT-B1-014	
5/32	0.156	NTFB-05FT-B1-014	
3/16	0.187	NTFB-06FT-B1-014	
7/32	0.218	NTFB-07FT-B1-014	
1/4	0.250	NTFB-08FT-B1-014	
9/32	0.281	NTFB-09FT-B1-014	
5/16	0.312	NTFB-10FT-B1-014	
11/32	0.344	NTFB-11FT-B1-014	
3/8	0.375	NTFB-12FT-B1-014	
13/32	0.406	NTFB-13FT-B1-014	
7/16	0.437	NTFB-14FT-B1-014	
1/2	0.500	NTFB-16FT-B1-014	
9/16	0.563	NTFB-18FT-B1-014	
5/8	0.625	NTFB-20FT-B1-014	
11/16	0.688	NTFB-22FT-B1-014	
3/4	0.750	NTFB-24FT-B1-014	

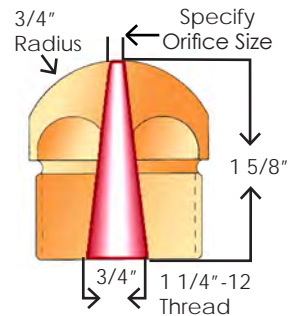

BIG EXTENDED TIPS

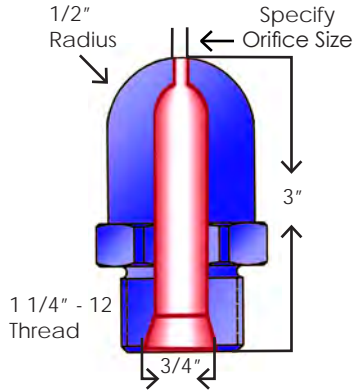

- ◆ High Quality Steel
- ◆ High Quality Copper Alloy
- ◆ Thread Size 1 1/4" - 12
- ◆ 3" Length O.A.
- ◆ 1 1/2" O.D.
- ◆ 1/2" & 3/4" Radius

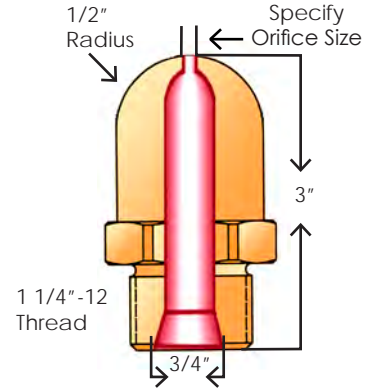

1/2" Radius

High Quality Steel			
Radius	Orifice	Part Number	
1/2"	1/16	0.062	NTFA-02GP-S1-030
	3/32	0.093	NTFA-03GP-S1-030
	1/8	0.125	NTFA-04GP-S1-030
	5/32	0.156	NTFA-05GP-S1-030
	3/16	0.187	NTFA-06GP-S1-030
	7/32	0.218	NTFA-07GP-S1-030
	1/4	0.250	NTFA-08GP-S1-030
	9/32	0.281	NTFA-09GP-S1-030
	5/16	0.312	NTFA-10GP-S1-030
	11/32	0.344	NTFA-11GP-S1-030
	3/8	0.375	NTFA-12GP-S1-030
	13/32	0.406	NTFA-13GP-S1-030
	7/16	0.437	NTFA-14GP-S1-030
	1/2	0.500	NTFA-16GP-S1-030
	9/16	0.563	NTFA-18GP-S1-030
	5/8	0.625	NTFA-20GP-S1-030
11/16	0.688	NTFA-22GP-S1-030	
3/4	0.750	NTFA-24GP-S1-030	

High Quality Copper Alloy			
Radius	Orifice	Part Number	
1/2"	1/16	0.062	NTFA-02GP-B1-030
	3/32	0.093	NTFA-03GP-B1-030
	1/8	0.125	NTFA-04GP-B1-030
	5/32	0.156	NTFA-05GP-B1-030
	3/16	0.187	NTFA-06GP-B1-030
	7/32	0.218	NTFA-07GP-B1-030
	1/4	0.250	NTFA-08GP-B1-030
	9/32	0.281	NTFA-09GP-B1-030
	5/16	0.312	NTFA-10GP-B1-030
	11/32	0.344	NTFA-11GP-B1-030
	3/8	0.375	NTFA-12GP-B1-030
	13/32	0.406	NTFA-13GP-B1-030
	7/16	0.437	NTFA-14GP-B1-030
	1/2	0.500	NTFA-16GP-B1-030
	9/16	0.563	NTFA-18GP-B1-030
	5/8	0.625	NTFA-20GP-B1-030
11/16	0.688	NTFA-22GP-B1-030	
3/4	0.750	NTFA-24GP-B1-030	

3/4" Radius

High Quality Steel			
Radius	Orifice	Part Number	
3/4"	1/16	0.062	NTFB-02GP-S1-030
	3/32	0.093	NTFB-03GP-S1-030
	1/8	0.125	NTFB-04GP-S1-030
	5/32	0.156	NTFB-05GP-S1-030
	3/16	0.187	NTFB-06GP-S1-030
	7/32	0.218	NTFB-07GP-S1-030
	1/4	0.250	NTFB-08GP-S1-030
	9/32	0.281	NTFB-09GP-S1-030
	5/16	0.312	NTFB-10GP-S1-030
	11/32	0.344	NTFB-11GP-S1-030
	3/8	0.375	NTFB-12GP-S1-030
	13/32	0.406	NTFB-13GP-S1-030
	7/16	0.437	NTFB-14GP-S1-030
	1/2	0.500	NTFB-16GP-S1-030
	9/16	0.563	NTFB-18GP-S1-030
	5/8	0.625	NTFB-20GP-S1-030
11/16	0.688	NTFB-22GP-S1-030	
3/4	0.750	NTFB-24GP-S1-030	

High Quality Copper Alloy			
Radius	Orifice	Part Number	
3/4"	1/16	0.062	NTFB-02GP-B1-030
	3/32	0.093	NTFB-03GP-B1-030
	1/8	0.125	NTFB-04GP-B1-030
	5/32	0.156	NTFB-05GP-B1-030
	3/16	0.187	NTFB-06GP-B1-030
	7/32	0.218	NTFB-07GP-B1-030
	1/4	0.250	NTFB-08GP-B1-030
	9/32	0.281	NTFB-09GP-B1-030
	5/16	0.312	NTFB-10GP-B1-030
	11/32	0.344	NTFB-11GP-B1-030
	3/8	0.375	NTFB-12GP-B1-030
	13/32	0.406	NTFB-13GP-B1-030
	7/16	0.437	NTFB-14GP-B1-030
	1/2	0.500	NTFB-16GP-B1-030
	9/16	0.563	NTFB-18GP-B1-030
	5/8	0.625	NTFB-20GP-B1-030
11/16	0.688	NTFB-22GP-B1-030	
3/4	0.750	NTFB-24GP-B1-030	

BIG EXTENDED TIPS

- ◆ High Quality Steel
- ◆ Thread Size 1 1/4" - 12
- ◆ 4" & 5" Length O.A.
- ◆ 1/2" Radius
- ◆ 1 1/2" O.D.

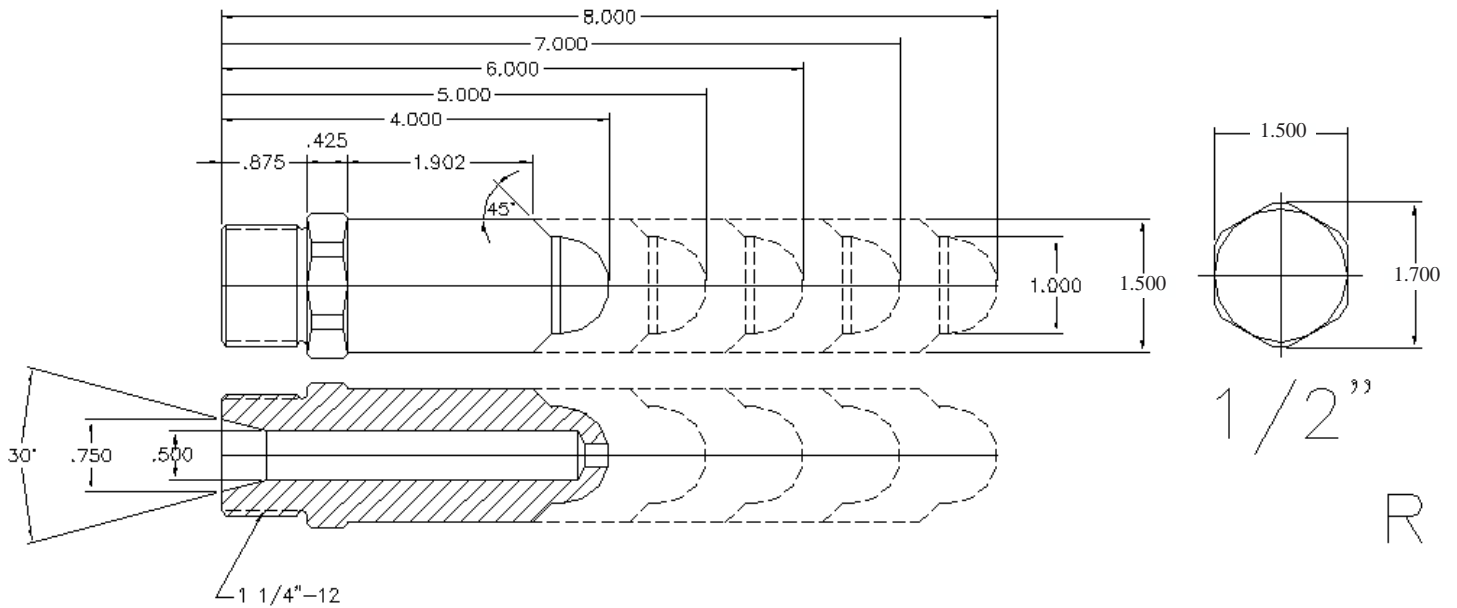

High Quality Steel				
Length	Radius	Orifice	Part Number	
4"	1/2"	1/16	0.062	NTFA-02GP-S1-040
		3/32	0.093	NTFA-03GP-S1-040
		1/8	0.125	NTFA-04GP-S1-040
		5/32	0.156	NTFA-05GP-S1-040
		3/16	0.187	NTFA-06GP-S1-040
		7/32	0.218	NTFA-07GP-S1-040
		1/4	0.250	NTFA-08GP-S1-040
		9/32	0.281	NTFA-09GP-S1-040
		5/16	0.312	NTFA-10GP-S1-040
		11/32	0.344	NTFA-11GP-S1-040
		3/8	0.375	NTFA-12GP-S1-040
		13/32	0.406	NTFA-13GP-S1-040
		7/16	0.437	NTFA-14GP-S1-040
		1/2	0.500	NTFA-16GP-S1-040
9/16	0.563	NTFA-18GP-S1-040		
5/8	0.625	NTFA-20GP-S1-040		
11/16	0.688	NTFA-22GP-S1-040		
3/4	0.750	NTFA-24GP-S1-040		

High Quality Steel				
Length	Radius	Orifice	Part Number	
5"	1/2"	1/16	0.062	NTFA-02GP-S1-050
		3/32	0.093	NTFA-03GP-S1-050
		1/8	0.125	NTFA-04GP-S1-050
		5/32	0.156	NTFA-05GP-S1-050
		3/16	0.187	NTFA-06GP-S1-050
		7/32	0.218	NTFA-07GP-S1-050
		1/4	0.250	NTFA-08GP-S1-050
		9/32	0.281	NTFA-09GP-S1-050
		5/16	0.312	NTFA-10GP-S1-050
		11/32	0.344	NTFA-11GP-S1-050
		3/8	0.375	NTFA-12GP-S1-050
		13/32	0.406	NTFA-13GP-S1-050
		7/16	0.437	NTFA-14GP-S1-050
		1/2	0.500	NTFA-16GP-S1-050
9/16	0.563	NTFA-18GP-S1-050		
5/8	0.625	NTFA-20GP-S1-050		
11/16	0.688	NTFA-22GP-S1-050		
3/4	0.750	NTFA-24GP-S1-050		

BIG EXTENDED TIPS

- ◆ High Quality Steel
- ◆ Thread Size 1 1/4" - 12
- ◆ 4" & 5" Length O.A.
- ◆ 3/4" Radius
- ◆ 1 1/2" O.D.

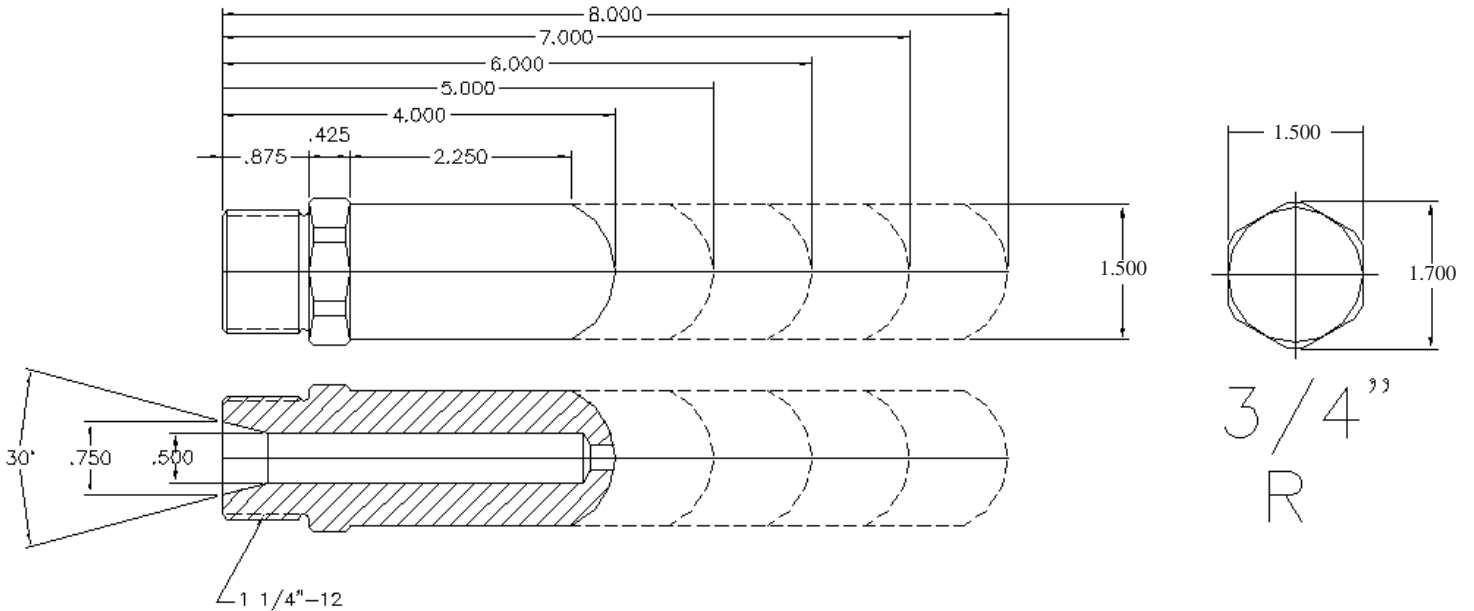

High Quality Steel				
Length	Radius	Orifice		Part Number
4"	3/4"	1/16	0.062	NTFB-02GP-S1-040
		3/32	0.093	NTFB-03GP-S1-040
		1/8	0.125	NTFB-04GP-S1-040
		5/32	0.156	NTFB-05GP-S1-040
		3/16	0.187	NTFB-06GP-S1-040
		7/32	0.218	NTFB-07GP-S1-040
		1/4	0.250	NTFB-08GP-S1-040
		9/32	0.281	NTFB-09GP-S1-040
		5/16	0.312	NTFB-10GP-S1-040
		11/32	0.344	NTFB-11GP-S1-040
		3/8	0.375	NTFB-12GP-S1-040
		13/32	0.406	NTFB-13GP-S1-040
		7/16	0.437	NTFB-14GP-S1-040
		1/2	0.500	NTFB-16GP-S1-040
		9/16	0.563	NTFB-18GP-S1-040
		5/8	0.625	NTFB-20GP-S1-040
11/16	0.688	NTFB-22GP-S1-040		
3/4	0.750	NTFB-24GP-S1-040		

High Quality Steel				
Length	Radius	Orifice		Part Number
5"	3/4"	1/16	0.062	NTFB-02GP-S1-050
		3/32	0.093	NTFB-03GP-S1-050
		1/8	0.125	NTFB-04GP-S1-050
		5/32	0.156	NTFB-05GP-S1-050
		3/16	0.187	NTFB-06GP-S1-050
		7/32	0.218	NTFB-07GP-S1-050
		1/4	0.250	NTFB-08GP-S1-050
		9/32	0.281	NTFB-09GP-S1-050
		5/16	0.312	NTFB-10GP-S1-050
		11/32	0.344	NTFB-11GP-S1-050
		3/8	0.375	NTFB-12GP-S1-050
		13/32	0.406	NTFB-13GP-S1-050
		7/16	0.437	NTFB-14GP-S1-050
		1/2	0.500	NTFB-16GP-S1-050
		9/16	0.563	NTFB-18GP-S1-050
		5/8	0.625	NTFB-20GP-S1-050
11/16	0.688	NTFB-22GP-S1-050		
3/4	0.750	NTFB-24GP-S1-050		

BIG EXTENDED TIPS

- ◆ High Quality Steel
- ◆ Thread Size 1 1/4" - 12
- ◆ 6", 7" & 8" Length O.A.
 - ◆ 1/2" & 3/4" Radius
 - ◆ 1 1/2" O.D.

High Quality Steel				
Length	Radius	Orifice	Part Number	
6"	1/2"	1/16	0.062	NTFA-02GP-S1-060
		3/32	0.093	NTFA-03GP-S1-060
		1/8	0.125	NTFA-04GP-S1-060
		5/32	0.156	NTFA-05GP-S1-060
		3/16	0.187	NTFA-06GP-S1-060
		7/32	0.218	NTFA-07GP-S1-060
		1/4	0.250	NTFA-08GP-S1-060
		9/32	0.281	NTFA-09GP-S1-060
		5/16	0.312	NTFA-10GP-S1-060
		11/32	0.344	NTFA-11GP-S1-060
		3/8	0.375	NTFA-12GP-S1-060
		13/32	0.406	NTFA-13GP-S1-060
		7/16	0.437	NTFA-14GP-S1-060
		1/2	0.500	NTFA-16GP-S1-060
		9/16	0.563	NTFA-18GP-S1-060
		5/8	0.625	NTFA-20GP-S1-060
		11/16	0.688	NTFA-22GP-S1-060
		3/4	0.750	NTFA-24GP-S1-060

High Quality Steel			
Radius	Orifice	Part Number	
3/4"	1/16	0.062	NTFB-02GP-S1-060
	3/32	0.093	NTFB-03GP-S1-060
	1/8	0.125	NTFB-04GP-S1-060
	5/32	0.156	NTFB-05GP-S1-060
	3/16	0.187	NTFB-06GP-S1-060
	7/32	0.218	NTFB-07GP-S1-060
	1/4	0.250	NTFB-08GP-S1-060
	9/32	0.281	NTFB-09GP-S1-060
	5/16	0.312	NTFB-10GP-S1-060
	11/32	0.344	NTFB-11GP-S1-060
	3/8	0.375	NTFB-12GP-S1-060
	13/32	0.406	NTFB-13GP-S1-060
	7/16	0.437	NTFB-14GP-S1-060
	1/2	0.500	NTFB-16GP-S1-060
	9/16	0.563	NTFB-18GP-S1-060
	5/8	0.625	NTFB-20GP-S1-060
	11/16	0.688	NTFB-22GP-S1-060
	3/4	0.750	NTFB-24GP-S1-060

High Quality Steel				
Length	Radius	Orifice	Part Number	
7"	1/2"	1/16	0.062	NTFA-02GP-S1-070
		3/32	0.093	NTFA-03GP-S1-070
		1/8	0.125	NTFA-04GP-S1-070
		5/32	0.156	NTFA-05GP-S1-070
		3/16	0.187	NTFA-06GP-S1-070
		7/32	0.218	NTFA-07GP-S1-070
		1/4	0.250	NTFA-08GP-S1-070
		9/32	0.281	NTFA-09GP-S1-070
		5/16	0.312	NTFA-10GP-S1-070
		11/32	0.344	NTFA-11GP-S1-070
		3/8	0.375	NTFA-12GP-S1-070
		13/32	0.406	NTFA-13GP-S1-070
		7/16	0.437	NTFA-14GP-S1-070
		1/2	0.500	NTFA-16GP-S1-070
		9/16	0.563	NTFA-18GP-S1-070
		5/8	0.625	NTFA-20GP-S1-070
		11/16	0.688	NTFA-22GP-S1-070
		3/4	0.750	NTFA-24GP-S1-070

High Quality Steel			
Radius	Orifice	Part Number	
3/4"	1/16	0.062	NTFB-02GP-S1-070
	3/32	0.093	NTFB-03GP-S1-070
	1/8	0.125	NTFB-04GP-S1-070
	5/32	0.156	NTFB-05GP-S1-070
	3/16	0.187	NTFB-06GP-S1-070
	7/32	0.218	NTFB-07GP-S1-070
	1/4	0.250	NTFB-08GP-S1-070
	9/32	0.281	NTFB-09GP-S1-070
	5/16	0.312	NTFB-10GP-S1-070
	11/32	0.344	NTFB-11GP-S1-070
	3/8	0.375	NTFB-12GP-S1-070
	13/32	0.406	NTFB-13GP-S1-070
	7/16	0.437	NTFB-14GP-S1-070
	1/2	0.500	NTFB-16GP-S1-070
	9/16	0.563	NTFB-18GP-S1-070
	5/8	0.625	NTFB-20GP-S1-070
	11/16	0.688	NTFB-22GP-S1-070
	3/4	0.750	NTFB-24GP-S1-070

High Quality Steel				
Length	Radius	Orifice	Part Number	
8"	1/2"	1/16	0.062	NTFA-02GP-S1-080
		3/32	0.093	NTFA-03GP-S1-080
		1/8	0.125	NTFA-04GP-S1-080
		5/32	0.156	NTFA-05GP-S1-080
		3/16	0.187	NTFA-06GP-S1-080
		7/32	0.218	NTFA-07GP-S1-080
		1/4	0.250	NTFA-08GP-S1-080
		9/32	0.281	NTFA-09GP-S1-080
		5/16	0.312	NTFA-10GP-S1-080
		11/32	0.344	NTFA-11GP-S1-080
		3/8	0.375	NTFA-12GP-S1-080
		13/32	0.406	NTFA-13GP-S1-080
		7/16	0.437	NTFA-14GP-S1-080
		1/2	0.500	NTFA-16GP-S1-080
		9/16	0.563	NTFA-18GP-S1-080
		5/8	0.625	NTFA-20GP-S1-080
		11/16	0.688	NTFA-22GP-S1-080
		3/4	0.750	NTFA-24GP-S1-080

High Quality Steel			
Radius	Orifice	Part Number	
3/4"	1/16	0.062	NTFB-02GP-S1-080
	3/32	0.093	NTFB-03GP-S1-080
	1/8	0.125	NTFB-04GP-S1-080
	5/32	0.156	NTFB-05GP-S1-080
	3/16	0.187	NTFB-06GP-S1-080
	7/32	0.218	NTFB-07GP-S1-080
	1/4	0.250	NTFB-08GP-S1-080
	9/32	0.281	NTFB-09GP-S1-080
	5/16	0.312	NTFB-10GP-S1-080
	11/32	0.344	NTFB-11GP-S1-080
	3/8	0.375	NTFB-12GP-S1-080
	13/32	0.406	NTFB-13GP-S1-080
	7/16	0.437	NTFB-14GP-S1-080
	1/2	0.500	NTFB-16GP-S1-080
	9/16	0.563	NTFB-18GP-S1-080
	5/8	0.625	NTFB-20GP-S1-080
	11/16	0.688	NTFB-22GP-S1-080
	3/4	0.750	NTFB-24GP-S1-080

CUSTOM NOZZLE TIPS

**AIC Custom Manufactures Nozzle Tips
to Your Specifications!**



With Outstanding Quality, Fast Service, and Low Prices...

CUSTOM NOZZLE TIP CHART

REQUEST FOR QUOTE

*Fill in the following basic dimension blanks
MAKE COPY TO FILL OUT AND FAX OR EMAIL

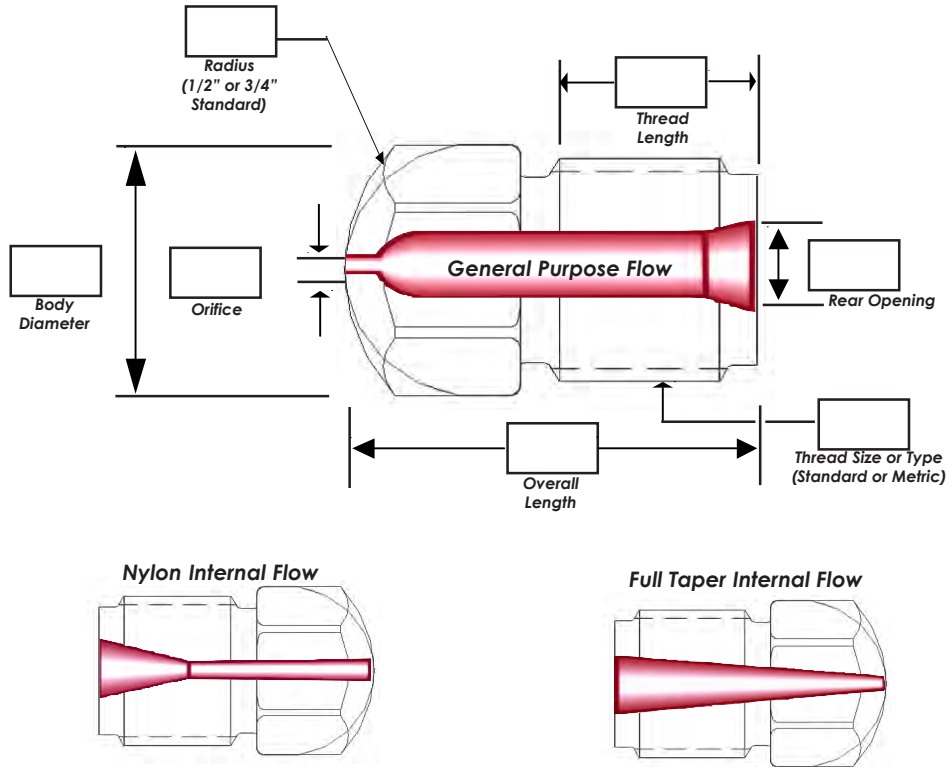

Fax: 810.227.5566

Specify:

Internal Flow Design: General Purpose Nylon Full Taper (check one)

Material To Be Molded: _____ Operating Temperature: _____

Diameter: _____ Quality: _____

Date: _____ Phone # _____ Fax#: _____

Company Name: _____

Contact Name: _____

Address: _____

City/State/Zip: _____

Fax this page with information for your custom nozzle tips.
Our nozzle tips are made from top quality alloy, stainless or tool steel
to meet your special needs.